

Model Based Design of Robust Vehicle Power Networks

Thorsten Gerke
Synopsisys GmbH

Alkiviadis Boulos
Jaguar Land Rover

ISBN 978-0-7680-1633-8

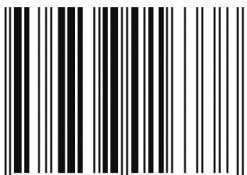

9 780768 016338

SAE *International*[™]

**2008 World Congress
Detroit, Michigan
April 14-17, 2008**

By mandate of the Engineering Meetings Board, this paper has been approved for SAE publication upon completion of a peer review process by a minimum of three (3) industry experts under the supervision of the session organizer.

All rights reserved. No part of this publication may be reproduced, stored in a retrieval system, or transmitted, in any form or by any means, electronic, mechanical, photocopying, recording, or otherwise, without the prior written permission of SAE.

For permission and licensing requests contact:

SAE Permissions
400 Commonwealth Drive
Warrendale, PA 15096-0001-USA
Email: permissions@sae.org
Tel: 724-772-4028
Fax: 724-776-3036



For multiple print copies contact:

SAE Customer Service
Tel: 877-606-7323 (inside USA and Canada)
Tel: 724-776-4970 (outside USA)
Fax: 724-776-0790
Email: CustomerService@sae.org

ISSN 0148-7191

Copyright © 2008 SAE International

Positions and opinions advanced in this paper are those of the author(s) and not necessarily those of SAE. The author is solely responsible for the content of the paper. A process is available by which discussions will be printed with the paper if it is published in SAE Transactions.

Persons wishing to submit papers to be considered for presentation or publication by SAE should send the manuscript or a 300 word abstract of a proposed manuscript to: Secretary, Engineering Meetings Board, SAE.

Printed in USA

Model Based Design of Robust Vehicle Power Networks

Thorsten Gerke
Synopsys GmbH

Alkiviadis Boulos
Jaguar Land Rover

Copyright © 2008 SAE International

ABSTRACT

Electrical power requirements for vehicles continue to increase. Future vehicle applications require the development of reliable and robust power supply strategies that operate over various ambient temperatures and driving conditions. Insufficient charge balance is one of the major concerns for conventional lead-acid battery systems when operated with limited charging times during short journeys or extreme climate conditions. For vehicle power supply analysis, a detailed understanding of the operational characteristics of the major components and how they interact as a part of the electric power system, including environmental and road conditions, is essential if the analysis is to aid system optimization. This paper presents a model based technique that enhances the process of vehicle electrical power system design. Vehicle system optimization using virtual prototypes has become critically important as more electrical features are added to future vehicles. Real vehicle data has been used to validate the models

performance against specific design acceptance criteria. The validation measurements have been performed for different battery and ambient temperature conditions in order to demonstrate the accurate prediction of the simulation and modeling approach.

TRENDS IN AUTOMOTIVE INDUSTRY

The power consumption of vehicle electrical systems has increased dramatically over the last 10 years. Increased comfort and convenience features, electrification of existing mechanical systems and improved safety are some of the main trends that contribute to such an electrical power increase on any vehicle model design [1, 2, 3].

The increase of electrical power consumption suggests the need to evaluate its impact upon fuel consumption, emissions and driving performance. This is because increased electrical power consumption invariably leads to larger power supply components that increase vehicle

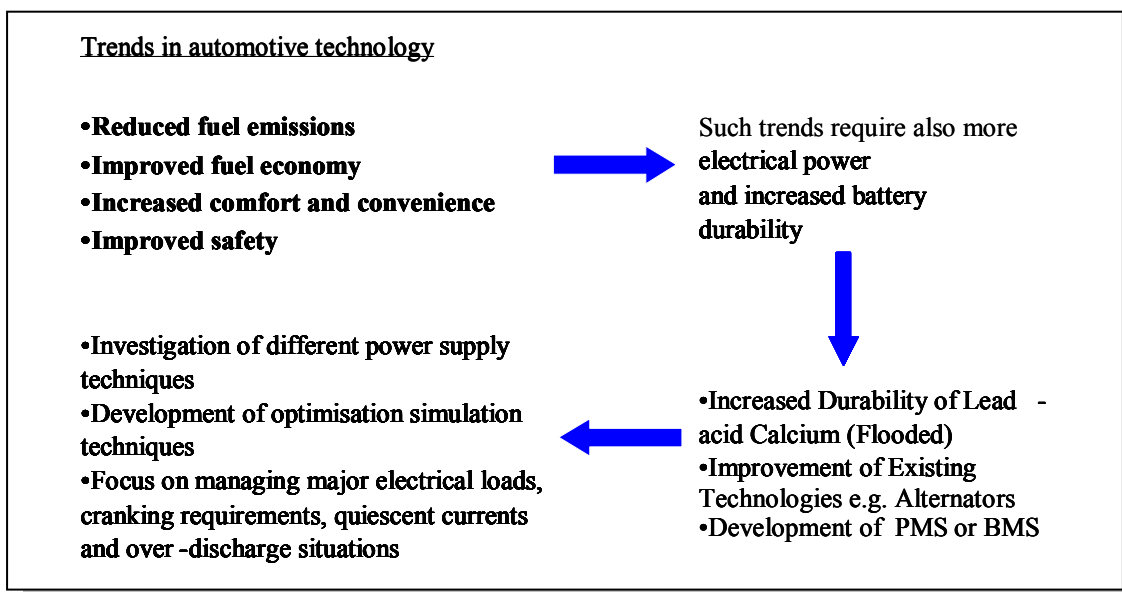

Figure 1: Trends in Automotive Technology

weight and the power drawn from the engine. Automotive manufacturers such as Jaguar and Land Rover, often develop power management techniques and integrate various electronic components (battery monitoring systems etc.) to accommodate the increase of vehicle electrical power consumption whilst minimizing any adverse effect upon the electrical components and the whole vehicle.

The development of dynamic simulation models that are based upon vehicle electrical systems provides a basis for analyzing complicated systems and predicting their performance and behavior when operating under a variety of different conditions. Modeling and simulation of various electrical power system configurations, combined with the development of new techniques for the optimization and control of a vehicle power network, can provide a competitive advantage to a vehicle manufacturer. Reduced manufacturing costs in terms of reduced delivery time of the product, improved engineering processes during development are some of the advantages that can be obtained from the use of new simulation models and techniques. Figure 1 illustrates the most important trends that are currently driving the automotive industry:

VEHICLE ELECTRICAL CHARGING SYSTEM AND ITS RELEVANT COMPONENTS

ARCHITECTURE OF VEHICLE POWER NETS

Present vehicle electrical charging systems are usually divided into three major parts (storage battery, alternator, and electrical features/loads). The starter and its associated wiring harness have not been taken into account in this development since the subject of this study is focused on simulations intended to investigate the battery charge balance of a vehicle under different ambient temperature and driving conditions. Figure 2 shows a schematic diagram of a vehicle charging system and how each part may be modeled as an equivalent circuit. Choosing and calibrating charging system

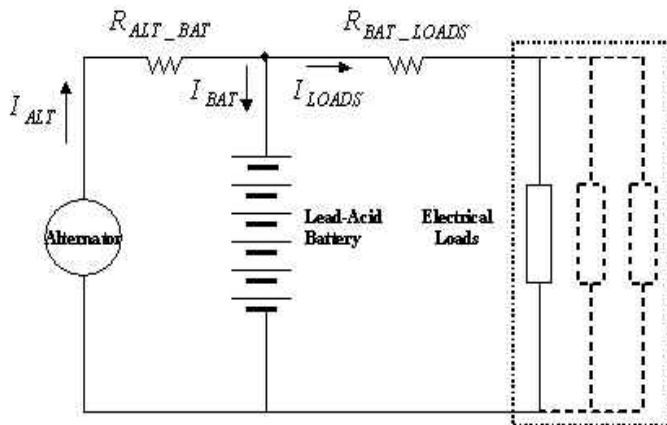

Figure 2: Vehicle Power Net Architecture

components very early in the development phase of a vehicle program will avoid reliability issues from under-sizing components and may prevent over-sizing the components which affects the overall cost of the vehicle in addition to increasing its fuel consumption and, sometimes, exhaust emissions. The ultimate design of an optimum charging system, which is appropriate for most operational conditions, is usually obtained through extensive charge balance experimental tests.

VEHICLE BATTERY

Traditionally lead-acid batteries are used for vehicles with electrical facilities for starting, lighting and ignition (SLI). The battery acts as a reservoir that has to supply various electrical loads and must be 'topped-up' continuously by the alternator, which acts as the main supplier of energy when the engine is running. In general, a lead-acid battery must be able to support

- Power requirements for starting a vehicle under a wide range of conditions, e.g. power requirements are dependent on temperature and upon the engine and transmission type.
- Power required by vehicle electrical systems when the engine is not running and/or to supplement the power provided by the alternator if the total vehicle electrical load exceeds the rated capacity of the alternator.

The state of charge (SOC) of the battery, therefore, is one of the most important parameters of a vehicle charging system. If more energy has been taken out of the battery than is put in then the charge balance is considered to be negative. If a negative balance prevails, the battery discharges and loses its capacity until it is fully discharged.

VEHICLE ALTERNATOR

The standard alternator used today is a Lundell, claw-pole, engine driven, 3-phase synchronous machine, which converts the rotational mechanical energy to electrical energy by electromagnetic induction. A synchronous generator is used because it allows the output voltage of the machine to be easily controlled by varying its field winding current. Alternators also contain a voltage regulator to ensure that the output voltage remains within safe levels to protect the system in which is implemented. For automotive applications the standard alternator is a claw-pole synchronous machine with a full wave rectifier to produce a Direct Current (DC) output. When the engine is running the alternator supplies the electrical power required by the vehicle electrical system. With appropriate gearing through the use of pulleys an alternator may operate within a speed range of 1500rpm to 22000 rpm. The maximum current output of the alternator depends on engine speed, temperature and

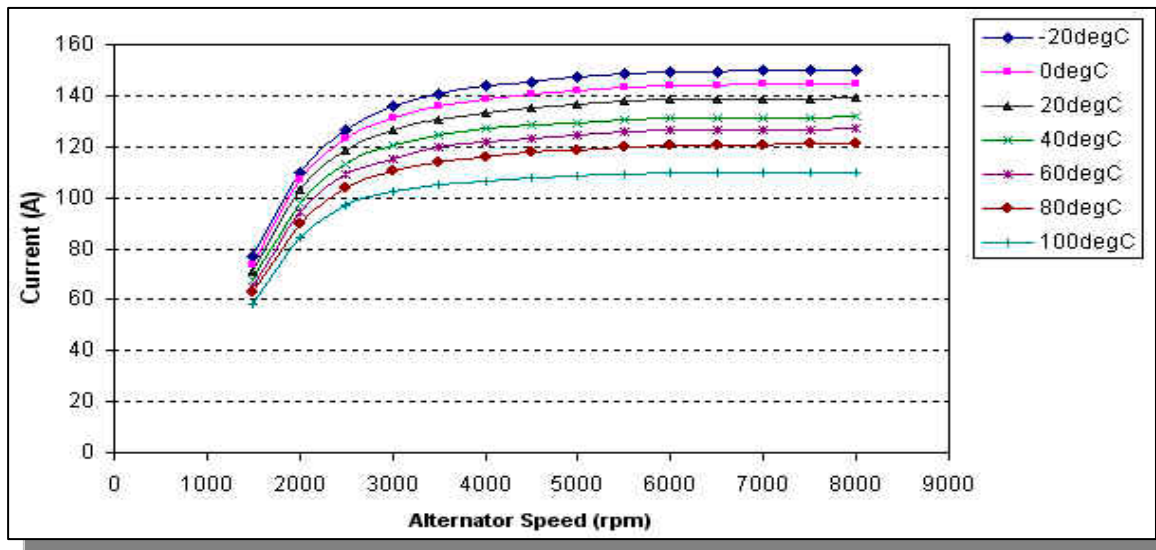

Figure 3: Typical alternator curves

operating voltage. More details on alternators may be found in [3]. Figure 3 shows typical alternator current output characteristics depending on temperature.

VEHICLE EQUIPMENT AND ELECTRICAL LOADS

A detailed and thorough examination was made of the electrical loads that were present on a high-end luxury automobile. These loads are separated into five main sections: engine based loads, exterior & interior lighting loads, audio/navigation loads, heating/comfort loads and

finally chassis loads. Table 1 shows a list of the identified loads that were considered in this study. The electrical loads that are listed above have various modes of operation. For example, the engine cooling fan system may use various methods of speed control, with the speed setting being dependent upon engine coolant temperature and air conditioning refrigerant pressure. Others, such as lighting or heated screens may be switched according to the mode of their operation (manual or auto). More details on the selection of modelling of individual loads are given in the following section.

SIMULATION BASED DESIGN OF ROBUST POWER NETWORKS

The Powernet Simulation model has been developed in SABER[®]. The SABER software offers the capability to model at different levels of abstraction from high-level behavioral models down to detailed component levels using available models developed for automotive use. Figure 4 illustrates the overall simulation based method for the analysis of vehicle power net architectures. This includes

MAIN CATEGORY	ELECTRICAL LOAD	NOMINAL POWER(W)
ENGINE LOAD	ENGINE COOLING FAN	0-540
	ENGINE RUNNING LOAD	200-340
EXTERIOR AND INTERIOR LIGHTING LOADS	SIDELIGHTS CLUSTER ILLUMINATION LICENSE-PLATE LIGHTS	45
	MAIN BEAM	110
	HIGH BEAM	110
	FRONT FOG LIGHTS	122
	REAR FOG LIGHTS	35
	MAP LIGHTS	20
	COURTESY LIGHTS	5
	BRAKE LIGHTS	20
	IN CAR ENTERTAINMENT/ NAVIGATION LOADS	TV
RADIO		20
CD UNIT		20
TELEMATICS		9
NAVIGATION		4
DVD + REAR SCREENS		27
HEATING/COMFORT LOADS	FRONT HEATED SEATS	220
	REAR HEATED SEATS	250
	FRONT HEATED SCREEN	610
	REAR HEATED SCREEN AND HEATED MIRRORS	270+47
	FRONT AND REAR CABIN FANS	0-400
	HEATED STEERING WHEEL	74
CHASSIS LOADS	AIR SUSPENSION	315

Table 1: Electrical Loads

- *Vehicle parameter input:* This includes all the necessary information used concerning the type of the vehicle, including details such as transmission ratios, engine idle speed, alternator pulley ratio etc.
- *Electrical component parameters input:* This includes information regarding the components of the vehicle electrical system such as batteries, alternators, harness circuits and specific vehicle systems/loads.

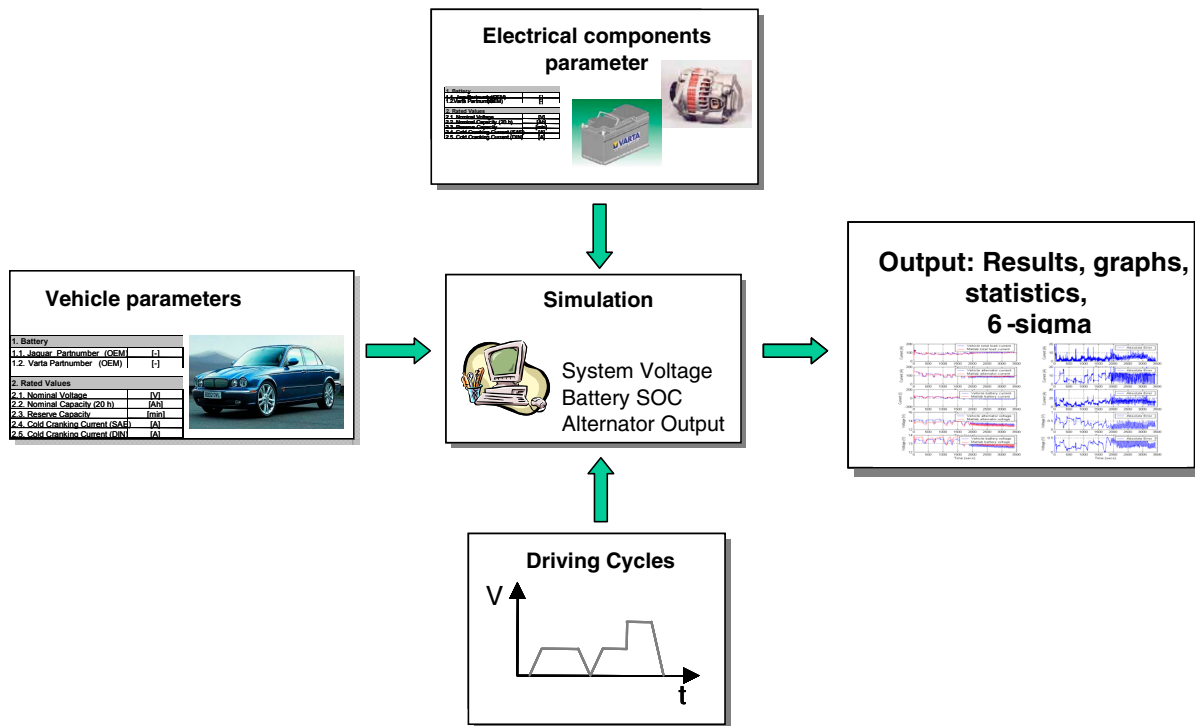

Figure 4: Simulation flow for Vehicle Power Net Systems

- *Driving cycles input:* This is the input data of the driving cycle that is to be used to evaluate the operation of the vehicle electrical power supply (i.e. city traffic cycles, start/stop cycles etc.).
- *Output:* Includes all the post processing analysis following each simulation run using SABER

OVERALL SIMULATION MODEL

The overall simulation model that is applied to the vehicle power net architecture is shown in figure 5. It contains three major parts

- Vehicle alternator
- Vehicle battery
- Electrical consumers (Loads)

What is the motivation and the benefits setting up such a simulation based engineering process? The reasons are quite obvious:

- Easy integration of new components through the variability of the existing component model libraries
- Construction and simulation of complex electromechanical systems that allow overall systems/individual components to be analyzed
- Provision to perform statistical analyses of the effects of variation of the system components
- Performance of Failure Modes & Effects Analysis (FMEA) at an early stage and help to provide confidence in the operation and capability of a specific charging system.

This simulation model of the vehicle power net can now be used and applied to driving cycle scenarios. Any changes like changing the size of battery, alternator type or number of loads and their corresponding power consumption can be considered right away. This allows performing a comprehensive validation of power net architectures across several platforms without needing a real hardware prototype.

VEHICLE BATTERY MODELS

The battery model provided by SABER represents an equivalent electrical circuit of a lead-acid battery based on the concept of a non-linear accumulator of the electrical charge. It is capable of simulating effects such as variation of available capacity and terminal voltage with discharge current, temperature-dependent self-discharge and capacity recovery following high rate discharges. Effects that are not simulated are cell-to-cell voltage variation, electrolyte mass balance effect, aging and state of health (SOH) and thermodynamic effects

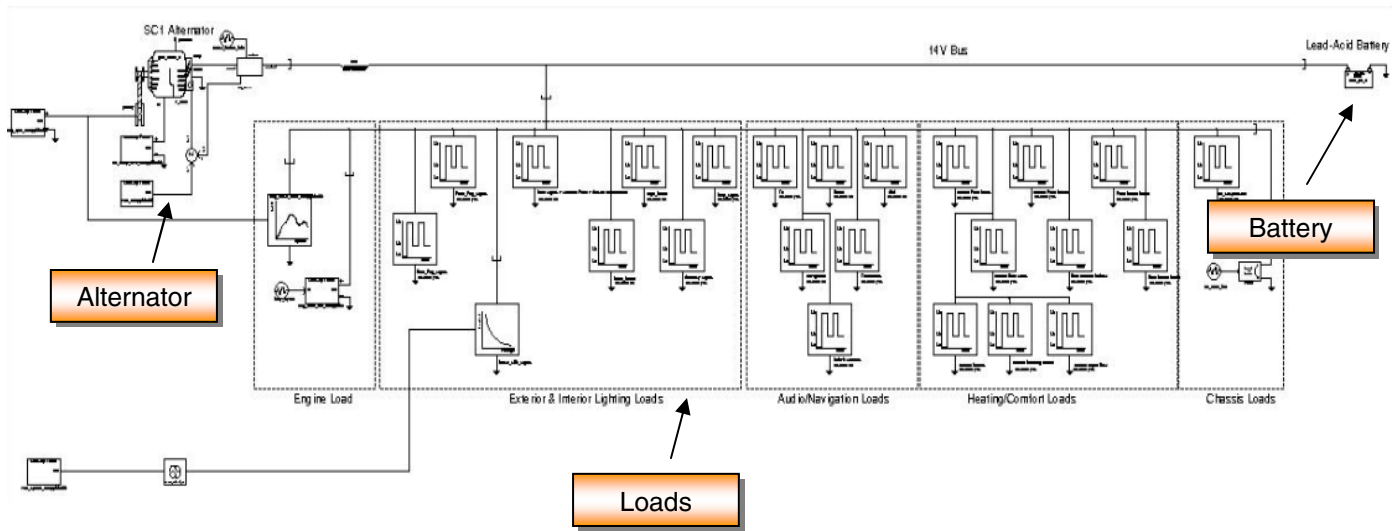

Figure 5: Overall Simulation Model of Vehicle Power Net System

such as Joule heat loss effects related to the charging/discharging life cycle of the battery. In order to complete the parameterization of the model for a specific type of battery, the SABER battery model provides a parameterization page including all the necessary parameters. In addition to manually entering the parameters SABER also provides a characterization tool that allows to graphically characterize the model. The input for the tool is measurements applied to the battery. Typical information like charge, discharge and step response is being used to automatically parameterize the model. The graphical user interface for the characterization tool is shown in figure 6. Models can be considered on different levels of abstraction including or

excluding thermal effects depending on the available set of data. The tool uses an optimizer to automatically extract the required parameter values from the measurements and feeds that into the simulation.

VEHICLE ALTERNATOR MODEL

In this study, a model is sought which provides good accuracy, fast simulation time and is relatively easy to set up. Alternator models that represent equivalent magnetic and electrical circuits provide sufficiently accurate emulation of alternator performance. However, such models generally require detailed information regarding alternator parameters, such as winding resistance,

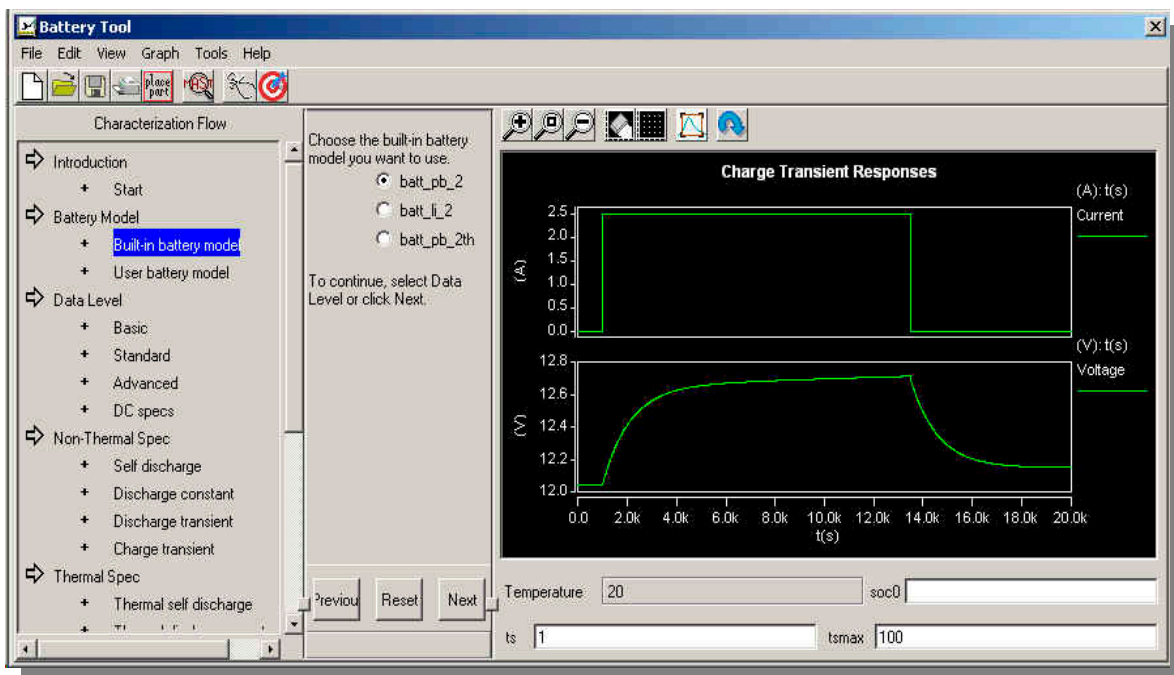

Figure 6: Characterization of the Battery Model

reactance and inductance, for example. Models that have been targeted to evaluating short time transient conditions rather than prolonged time periods require high computational power. For the comparatively steady state conditions that are used to evaluate electrical power supply performance, alternative models are required. Knowledge gained from creating and using alternator models suggested that a model which considered only specific alternator operational attributes, such as that provided by an existing SABER model, would be able to provide the accuracy required for the purpose of the

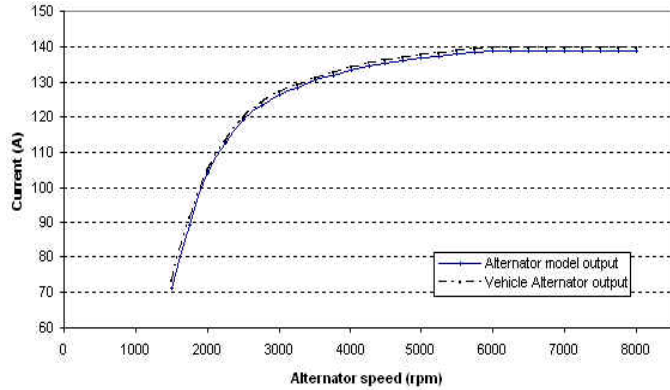

Figure 7: Comparison of measured and simulated Alternator Currents

SABER Powernet Simulation (SPS). This model is based upon an operative map that predicts current output depending upon engine speed, alternator air temperature and efficiency. An example of the alternator model performance compared with actual alternator data is given in Figure 7. Another effect that has been incorporated into the model used by the SPS attempts to replicate the transient effect upon the maximum alternator output current capability that occurs whilst the machine is warming up after engine start. It has been observed that, during this warm-up period which lasts approximately 10 minutes, the alternator generates a maximum current up to 10%-15% higher than the current claimed by the manufacturer's characteristic of output current vs. rotational speed. This occurs because the resistance of the rotor and stator windings of the alternator is reduced at lower temperatures before the alternator has heated up to a stabilized operational temperature. As the alternator becomes warmer, the resistance of the windings increases which gradually reduces its maximum output current capability. Therefore a 'boost factor' function has been added to the alternator model to increase its maximum current output capability for a certain period of time to match the actual observed behavior of real alternators.

VEHICLE LOADS

Static power load models have been used to represent electrical loads with known electrical power output and their operation depending on the system voltage and the manual (or automatic) operation by the driver (i.e. vehicle

lights, heated windows etc.). Loads depending on additional parameters other than system voltage, such as engine speed, thermostat operation, and brake pedal enabled (brake lights) should be modeled using a different modeling philosophy. Operative maps have been used as appropriate to represent the electrical loads when power-constant load models were judged as inadequate in providing a suitably accurate emulation. For example, when considering the engine cooling fan, the required fan speed in terms of duty cycle based upon the engine cooling requirements (i.e. air conditioning

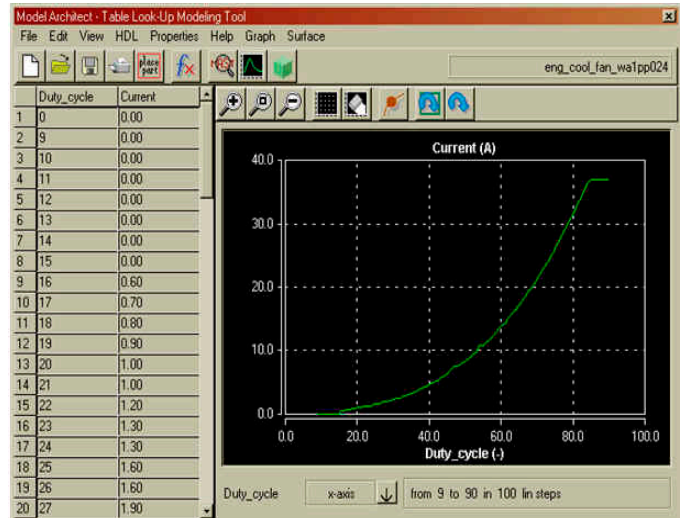

Figure 8: Cooling Fan Model

refrigerant pressure, coolant temperature) is determined by the Engine Management System (EMS). Figure 8 shows the SABER look-up table model of the engine cooling fan predicting its current consumption based on duty cycle.

DRIVE CYCLE SCENARIOS

Different driving cycle scenarios were performed and the simulation accuracy is compared against experiments carried out on development vehicles and from standard

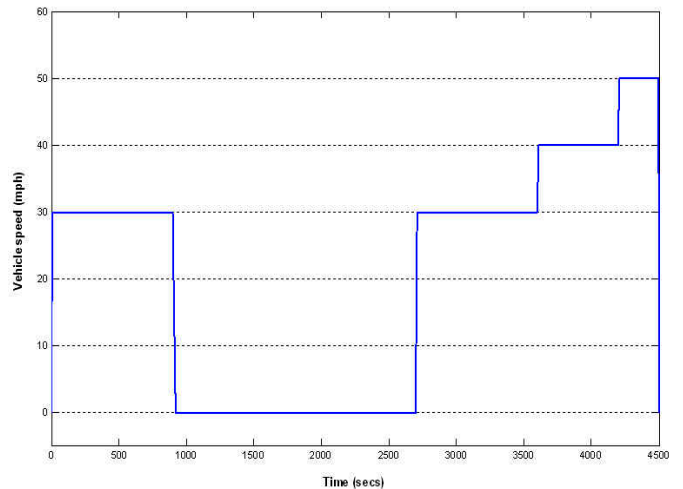

Figure 9: DID Drive Cycle Profile

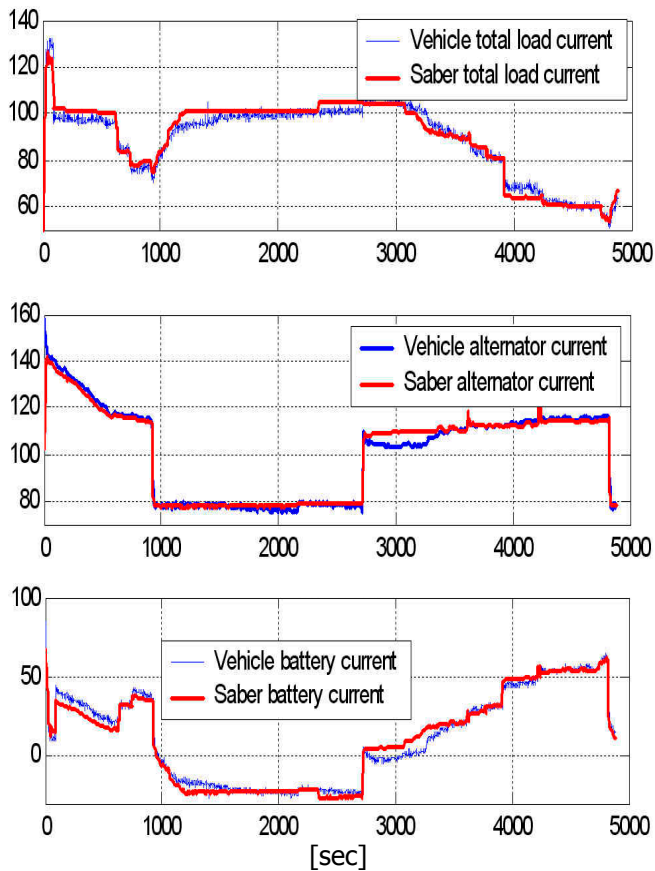

Figure 10: Load, Alternator and Battery Current DID Cycle +40°C

drive cycle conditions. The ambient air temperatures of these tests ranged between 0°C and 40°C with the battery SOC at the start of the test being set to 50% for a DID (figure 9) test. For the DID tests the SOC of the battery model is set at 50%, because this is the expected capacity of the battery in a ‘worst case scenario’ (i.e. long

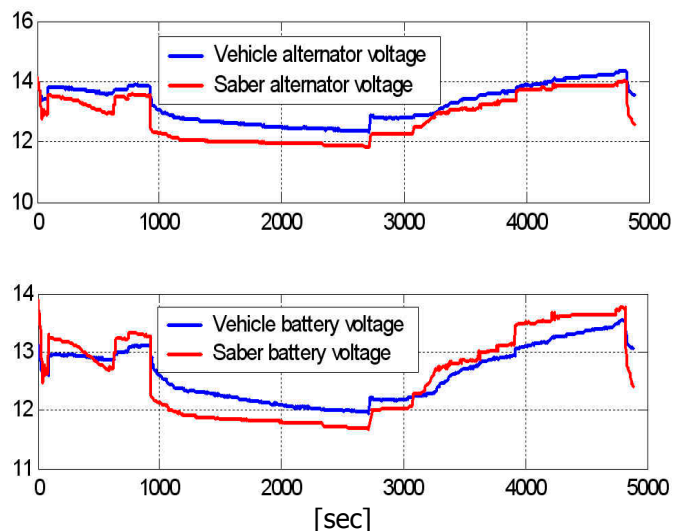

Figure 11: Alternator and Battery Voltages DID Cycle +40°C

stay car park with the vehicle at standstill for 31 days with all electrical loads switched off but alarm system on). The above tests provide the opportunity to compare how the different SOC levels affect the performance of the battery and the alternator models in a variety of conditions that may cause the battery to be charged and discharged. Figure 9 shows the profile of the vehicle speed for the DID cycle test, respectively. In the evaluation of the above system a variety of signals can be compared with experimental data. The selection of

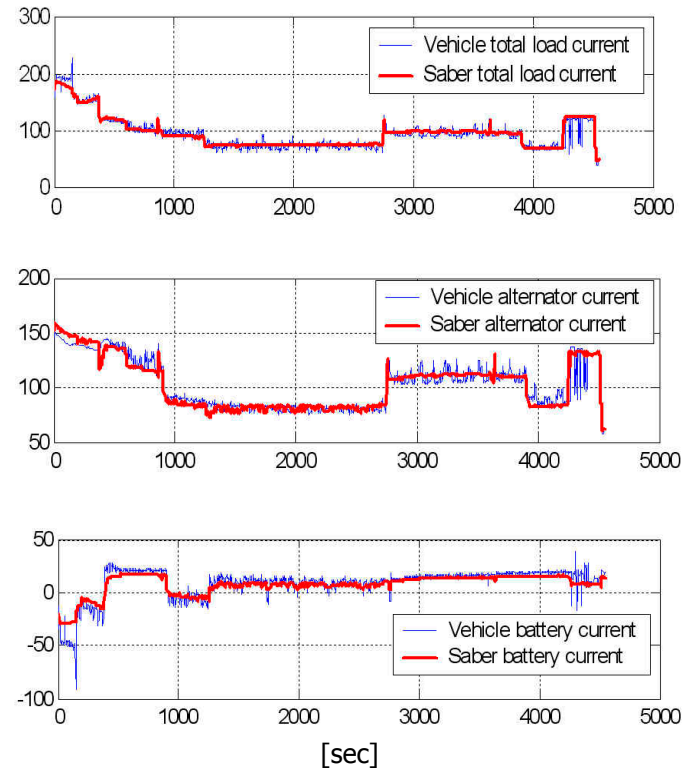
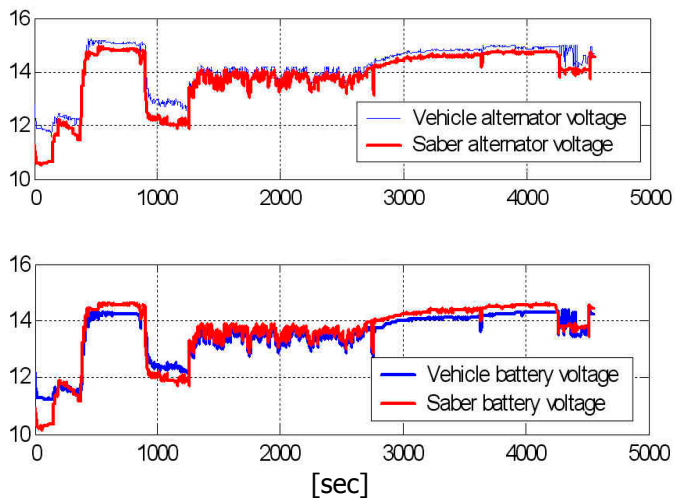

Figure 12: Load, Alternator and Battery Current DID Cycle 0°C

data for comparison was dependent upon the subject of the evaluation. In this study the following were selected in order to compare model performance with actual measured data.

- Alternator current output
- Battery current output
- Alternator voltage levels during charging & discharging cycles
- Battery voltage levels during charging & discharging cycles
- The total current consumption of the selected electrical loads

The simulation results for the electrical current and voltage for the DID cycle are shown in figure 10 to 13 under different temperature conditions. The resulted



**Figure 13: Load, Alternator and Battery Voltage
DID Cycle 0°C**

curves show a good agreement of the total simulated vehicle electrical load current to that measured from the test vehicle. It is worth noting that the actual vehicle load current is represented as a ‘noisy’ trace, particularly in lower ambient temperatures. This occurs because loads related to heating and passenger comfort, such as heated screens and heated seats, are repeatedly switched on and off to maintain a specific temperature. By comparison, such comfort loads in the simulation tool remain on all of the time with the electrical power being regulated to different levels according to ambient temperature. This issue could be addressed by modeling such temperature dependent loads differently, but after a careful consideration on the effect of such models on the overall accuracy of the SPS, this was considered to be minimal. It is also evident from the comparison of the simulated and the actual measured alternator currents that the alternator model current output shows a good agreement with the actual alternator output for the temperature range considered. The errors that are evident for the cold climate conditions are mostly caused by the repeated switching ON and OFF of the heating loads. However, the errors that occur in hot climate conditions, after the extended idle period, are related to alternator temperature for hot environmental climate conditions e.g. extremely high under-bonnet temperatures. In reality, it takes more time for the under-bonnet area to cool the alternator and this causes the actual alternator current to be lower than that predicted by the model. Finally, by examining the results, it is clear that the vehicle power net simulation model performed well.

ACCELERATING THE ENGINEERING PROCESS THROUGH SYSTEM SIMULATION

Validating new vehicle power net concepts are usually time consuming if they are done through real hardware prototyping approaches. Hardware prototypes are only available in the later design stages and a proof of

concept in the very early design stage is in most of the cases not possible. Detailed results about the power net can be obtained only in the later phase of the engineering process. Through system simulation it is possible to get results already very early. A proof of concept and different vehicle power net variants can be analyzed very quickly. If problems are discovered necessary changes can be applied to the simulation model and the system behavior is validated again. Unlike a change in the hardware prototype which is usually time consuming and cost intensive. It takes usually 12 months until the first vehicle hardware prototype is available. Before this time it is not possible to perform a validation of the power net implementation since measurements cannot be performed. A one time effort of 6 months is needed to set up the simulation based virtual vehicle prototype. The effort to set up later simulation models is less as most of the models can be derived from the previous vehicle model. This means the power net concepts can be validated several months before the actual hardware prototype becomes available. This is a significant benefit since the implementation of the vehicle can be adapted and improved before the hardware is assembled. In addition, the hardware testing consumes about 60% of the time of the entire engineering process and this can be enormously shortened but it is depend on the specific platform how much time saving can be achieved.

CONCLUSION

A simulation model for vehicle power supply analysis and design has been developed that allows confident prediction of the behavior and robustness of the vehicle electrical power supply system configurations being evaluated. Major components of a vehicle power supply such as the alternator, the battery and the electrical loads/features have been modeled and extended to match target hardware. The developed power net model has been validated using actual measured data obtained from trials performed on actual test vehicles under realistic environmental and drive cycle conditions. The reasoning behind this was that a developed simulation model has to provide a good level of accuracy, within specifically defined criteria to satisfy target levels for error between signals actually measured and signals obtained from the model, thus demonstrating its performance for a specified range of known driving conditions. The simulation results have shown good agreement with experimental results obtained from tests on actual vehicles and limitations in regard to correlation with actual vehicle data being clearly identified and noted. Simulation environments such as SABER provides the possibility to estimate the variance of major electrical components upon the performance of the vehicle electrical system and will help manufacturers to improve the robustness and reliability of their vehicles as well as reducing vehicle development lead times and costs.

REFERENCES

- [1] **E. Chowanietz**, *Automobile Electronics*, SAE International, 1994.
- [2] **R. Q. Riley**, *Alternative Cars in the 21st Century*, SAE, Chapter 5, 1994.
- [3] **Robert Bosch GmbH**, *Automotive Electric/Electronic Systems*, (Automotive Equipment Product Group, Department for Technical Information), 3rd Edition, 1988
- [4] **Myoungcho, S., Wootaik., L., and Daeho C.**, *Modelling and Simulation of Vehicle Electric Power System*, SAE 2001-01-3343, Automotive & Transportation Technology Congress & Exhibition, October 1-3, 2001.
- [5] **Boulos, A. M., Pacaud, C., Burnham, K. J. and Mahtani, J. L.**, *Validation of battery-alternator model against experimental data - A first step towards developing a future power supply system*, Journal of Automobile Engineering, Proceedings of the Institution of Mechanical Engineers (IMEchE), Part D, Vol. 218, pp 59-70, Jan 2004.
- [6] **Reasbeck, P. and Smith, J.G.**, *Batteries for Automotive Use*, (John Wiley & Sons inc., England), 1997.
- [7] **Thorsten Gerke, Carsten Petsch**, *Analysis of Vehicle Power Supply System using System Simulation*, SAE 2006, Detroit

CONTACTS

Thorsten Gerke

Technical Marketing Europe – SABER Product Line
Synopsys GmbH
Karl-Hammer-Schmidtstr. 34
85609 Aschheim/Dornach (Germany)
E-Mail: thorsten.gerke@synopsys.com
Phone: +49 89 99320 227

Alkiviadis Boulos

Power Supply Systems Engineer
Jaguar Cars Ltd.
Abbey Rd
Whitley
Coventry CV3 4LF (United Kingdom)
E-Mail: aboulos@jaguar.com
Phone: +44 24 76 20 6401