

Benefits of the RSoft Photonic System Design Suite to Optical and Photonic Component Manufacturers

Author

Jigesh Patel

Sr. Application Engineer

Introduction

It is common for manufacturers of optical and photonic components to use device modeling tools during the design and optimization stages of the product development cycle. Although most of these components are ultimately used in optical and photonic systems, system design considerations are often left to their customers and system designers.

In some cases, availability of component specifications (“specs”) and industry standards helps lessen the burden of in-house system-level testing. Optical and photonic component specs developed by industry associations and standards organizations consider trade-offs between the manufacturing technology and target system performance. The focus then shifts to manufacturing components that meet or exceed the specs, rather than investing in subsequent testing and verification of the components at the system level. The specs don’t always exist and can’t always keep up with emerging applications. Even when they exist, there are other drawbacks to this approach as examined later in this document.

Large corporations providing both component and system solutions often have independent expert teams for device and system design. Although close collaboration between these two groups is part of product development, their core, individual functionalities remain highly confined to each respective group. This white paper aims to show, with the help of a number of test-case studies, that optical and photonic component manufacturers and vendors of any size can benefit immensely from having a systems modeling tool—not only during the product development, but also during product marketing.

RSoft Photonic System Design Suite Overview

The three products that comprise the RSoft™ Photonic System Design Suite are OptSim™, OptSim Circuit and ModeSYS™. OptSim models single-mode fiber-based systems at the signal propagation level. OptSim Circuit is a modeling tool for next-generation photonic integrated circuits that operate with coupling and feedback of different optical and electrical signal paths. ModeSYS is a design and simulation tool for multimode fiber-based systems where both the temporal and spatial attributes of the optical signal propagation are taken into account. While all three products share the same graphical user interface (Figure 1) and work under a common platform, each can also function as a standalone product, providing a cost-effective, needs-based modular solution.

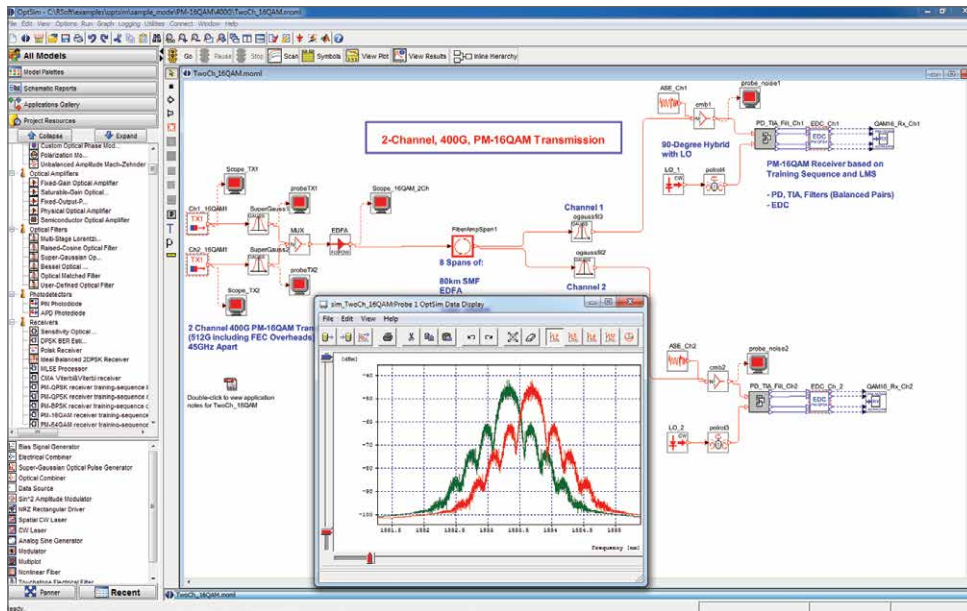

Figure 1: The graphical user interface (GUI) of the RSoft Photonic System Design Suite and an OptSim layout

Benefits to Component Manufacturers

As presented in the case studies in this document, the RSoft Photonic System Design Suite can benefit optical and photonic components manufacturers and vendors by streamlining the production process (savings in operating and capital expenditures), and helping boost revenue with product marketing opportunities.

The RSoft Photonic System Design Suite helps identify tolerances in component parameters that will have a major impact on system performance and vice versa. Monte Carlo multi-parameter scans over component variables can be carried out to obtain the stochastic bounds on system performance. Based on this information, processes can be improved to maximize system performance, and manufacturing costs can be saved by implementing less stringent tolerances that have minimal impact on system performance.

Simply meeting or exceeding the component specs does not guarantee a successful system. Multimode system designers know that a 10 Gbps transmitter coupled to a multimode fiber doesn't necessarily give a 10 Gbps fiber-optic link; coupling conditions and component offsets can significantly affect the system bandwidth. The RSoft system modeling tools help component vendors demonstrate how their clients can succeed with the vendors' components, thereby serving as an invaluable aid to product marketing. For example, a component vendor for reconfigurable optical add/drop multiplexer (ROADM) devices can seal the deal with their customers (typically, service providers) by demonstrating in OptSim how long-haul networks will achieve improved performance when multiple ROADMs are deployed.

Case Studies

To be helpful to a diverse group of component manufacturers, the case studies presented in this section cover components from both optics and photonics. Rather than focusing on the modeling aspects, the discussion is geared towards how product development and product marketing teams at companies of any size can benefit from RSoft Photonic System Design Suite.

The test cases are divided into three categories:

- Case studies based on component measurements
- Case studies based on the co-simulation with components modeling tools
- Case study based on manual exchange of data between the modeling tools

A. Case Studies Based on Component Measurements

A.1: Reconfigurable Optical Add/Drop Multiplexer (ROADM)

ROADM is a fiber-optic network element that allows network operators to efficiently manage data traffic over their agile optical networks, and provides what is commonly referred to as the “flexgrid” (any wavelength, any node, any time) functionality while keeping operational costs low. Depending upon the scale of the optical transport network, there can be tens or hundreds of ROADMs deployed. Even though each ROADM may be able to support the desired data rate, multiple ROADMs cause narrowing of bandwidth and optical crosstalk—both of which negatively affect the data rate that can be supported.

During the technology selection process, network operators are often concerned with choosing the ROADM that minimizes optical power losses (resulting from insertion and polarization dependent losses), crosstalk and the amount of bandwidth narrowing.

As shown in Figure 2, ROADM manufacturers can use measured frequency response of a single ROADM in OptSim to demonstrate to network operators how the component would perform in a network when multiple ROADMs are installed.

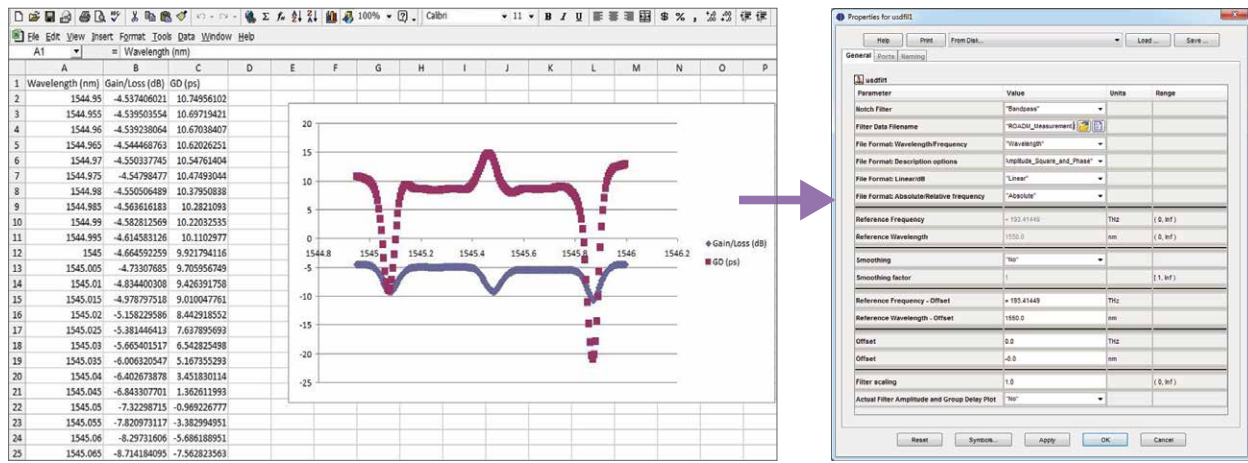

Figure 2: Using measured characteristics of a ROADM (left) in OptSim (right) to analyze its performance in an optical network

A.2: Dispersion Compensating Gratings

Compensation of fiber dispersion is crucial in long-haul fiber optic links since effective compensation of dispersion helps transmit faster data rates to longer distances. Fiber Bragg Grating (FBG) is one way to optically compensate for fiber dispersion.

Manufacturers of FBG devices use an optical vector analyzer to measure the Jones transfer characteristics of the devices. OptSim helps model the rest of the fiber optic link and analyze how effective the measured FBG device is at compensating for the dispersion when deployed in a system. Figure 3 shows such a setup.

This analysis is important to device manufacturers not only to understand the device behavior, but also to demonstrate to their clients how the client system would perform with their component.

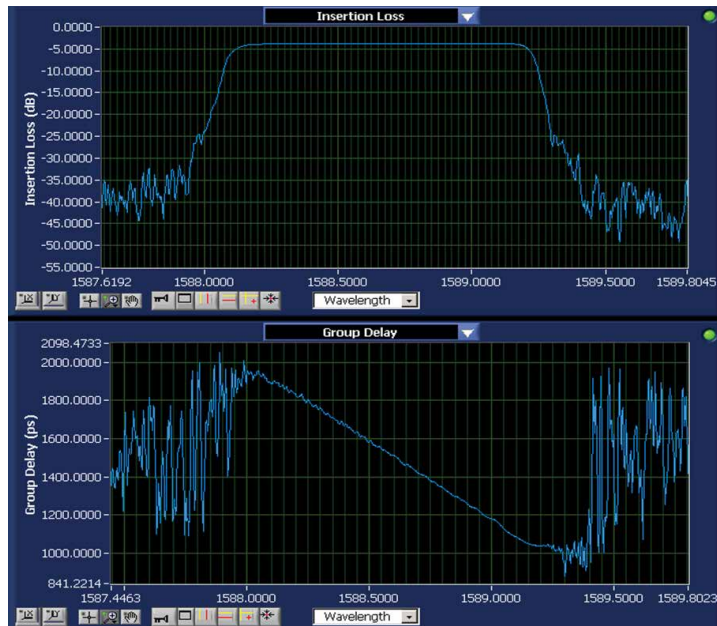

(a) Jones transfer matrix measurements from an optical vector analyzer

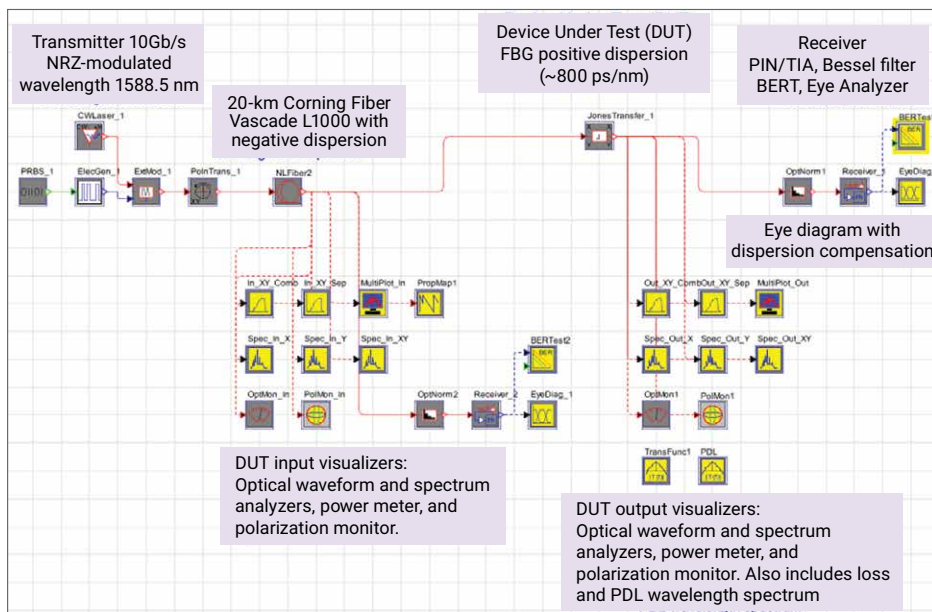

(b) Analyzing measured dispersion compensating grating in OptSim

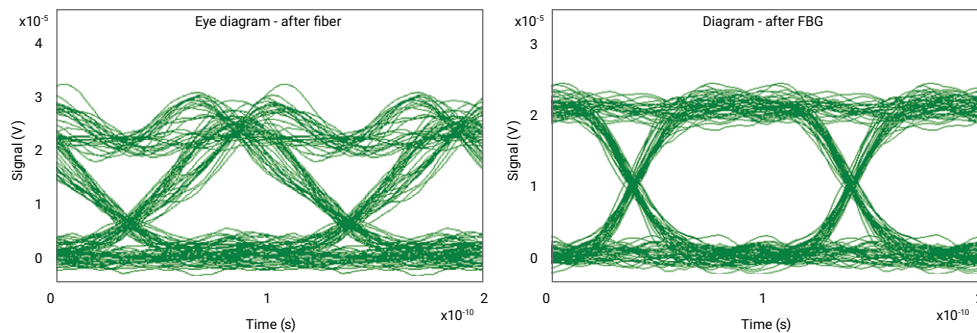

Figure 3: Using measured characteristics of a dispersion grating (a) in OptSim to analyze its performance in an optical link (b)

B. Case Studies Based on the Co-Simulation with Component Modeling Tools

The RSoft Photonic System Design Suite, via its interfaces, can integrate the results from various component-level modeling tools using a single framework [1]. Figure 4 shows a schematic of some of the interfaces.

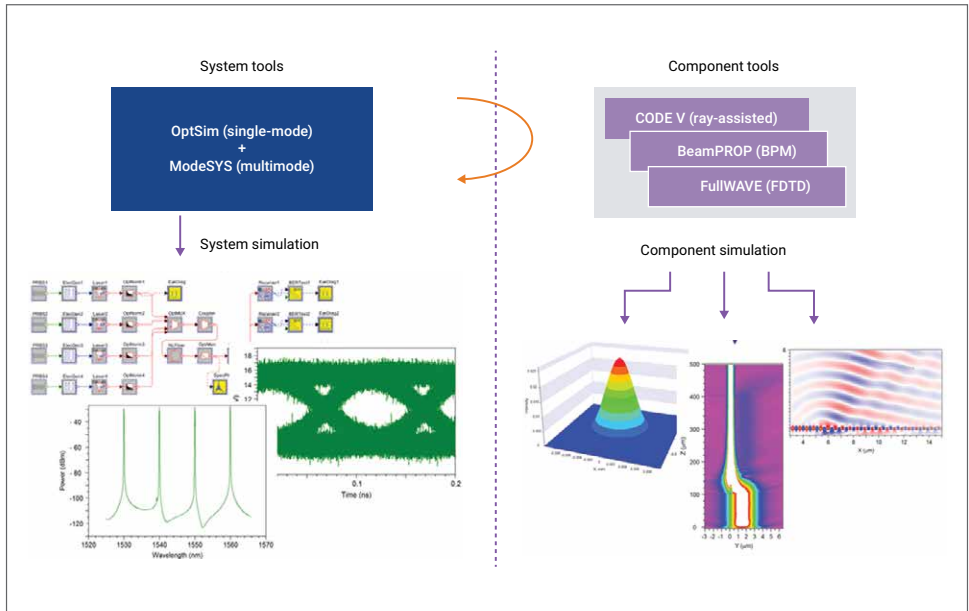

Figure 4: Co-simulation with components modeling tools

Co-simulation not only helps with creating rapid system prototypes, but also with assessing how variations in component manufacturing processes impact system performance. Manufacturing costs can be reduced with less stringent process controls for parameters when their variations have minimal system impact.

B.1: Catadioptric Lens Assembly for Fiber-to-Photodiode Coupling

This case study is based on a catadioptric lens assembly, as detailed in Ref. [2], utilizing a ball lens and a parabolic mirror to couple the output of a fiber into the photodiode. Figure 5 shows the layout in CODE V® that is analyzed in the RSoft Photonic System Design Suite using co-simulation.

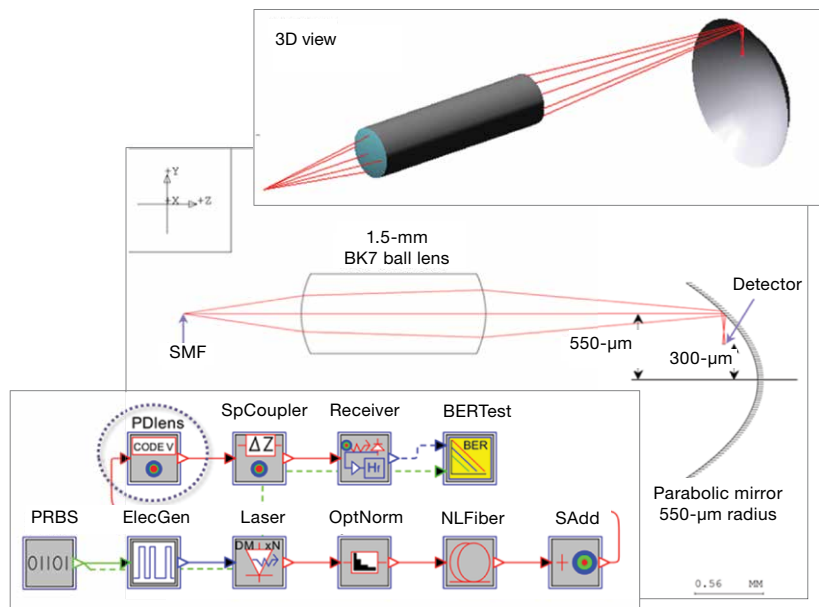

Figure 5: Co-simulation with CODE V to analyze fiber-to-photodiode coupling via a catadioptric lens assembly

Figure 6 shows fiber-to-detector coupling efficiency and the bit error rate, both as a function of fiber-detector misalignment.

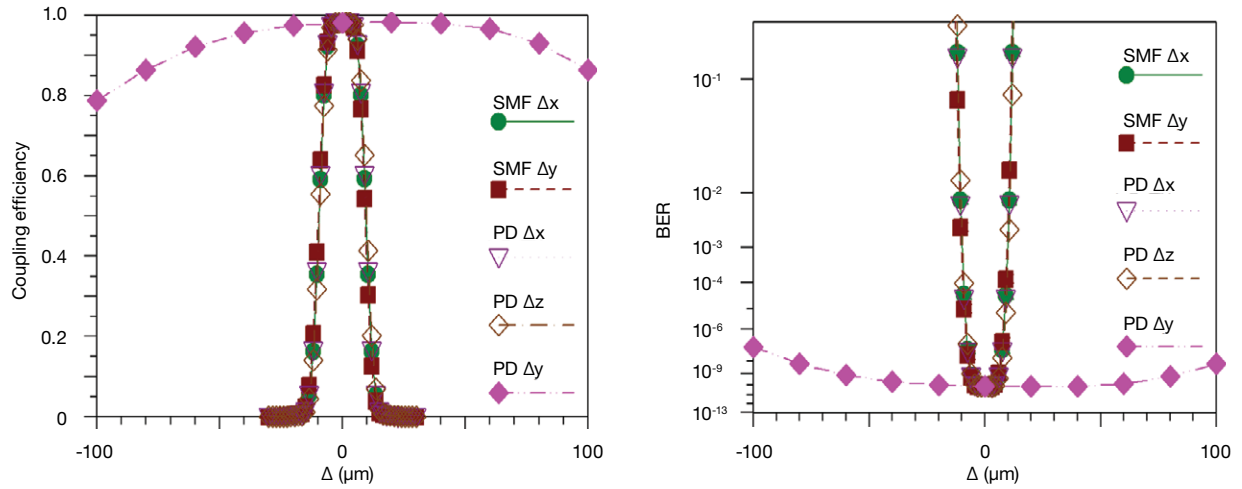

Figure 6: Fiber-to-detector coupling efficiency (left) and the system performance as a function of fiber-detector misalignments (right)

The study shows that both the coupling efficiency and system performance are less sensitive to the variations in the vertical placement of the photodiode with respect to the mirror.

B.2: Aspheric Lens Assembly for Coupling Between Transmitter and Multimode Fiber (MMF)

This case study is based on an aspheric polycarbonate lens assembly, as detailed in Ref. [3], for exploring its use as transmitter-to-multimode fiber coupling. Figure 7 shows the layout in CODE V that is analyzed in ModeSYS using co-simulation.

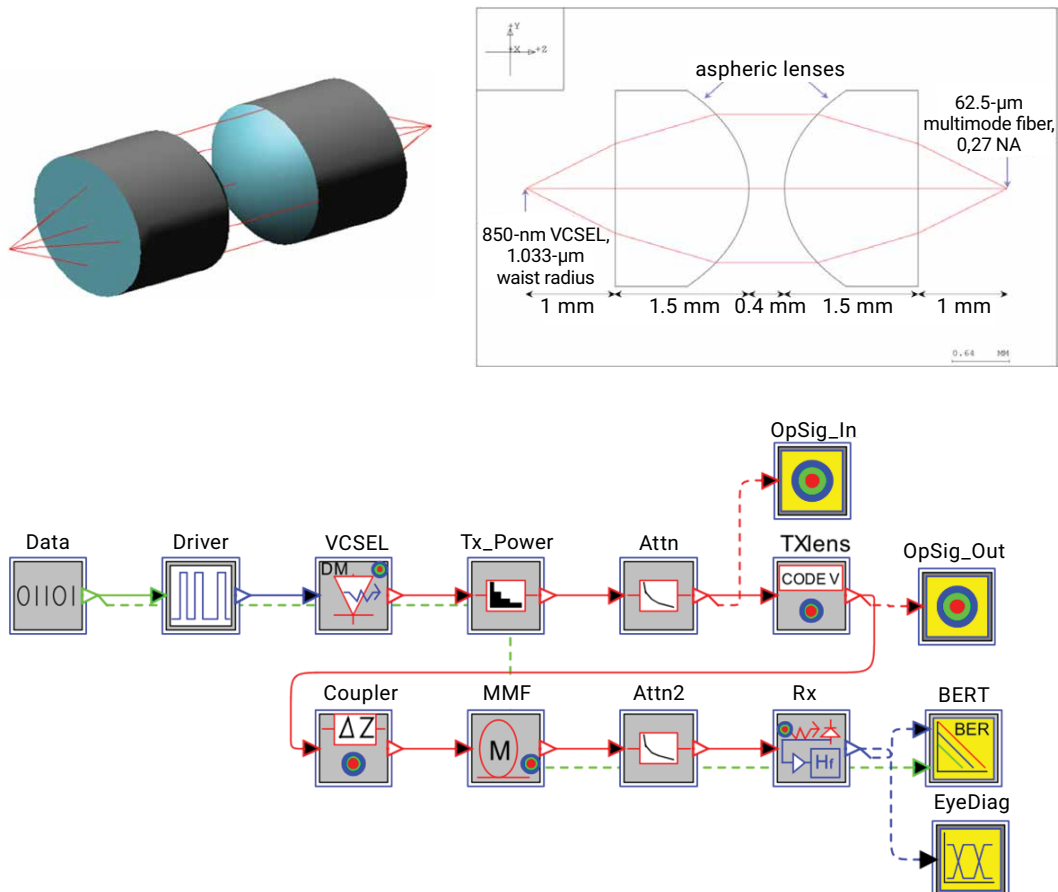

Figure 7: Aspheric lens assembly modeled in CODE V (top left and right) and used in the co-simulation with ModeSYS (lower layout)

Figure 8 shows fiber-to-detector coupling efficiency and the bit error rate both as a function of fiber-detector misalignment.

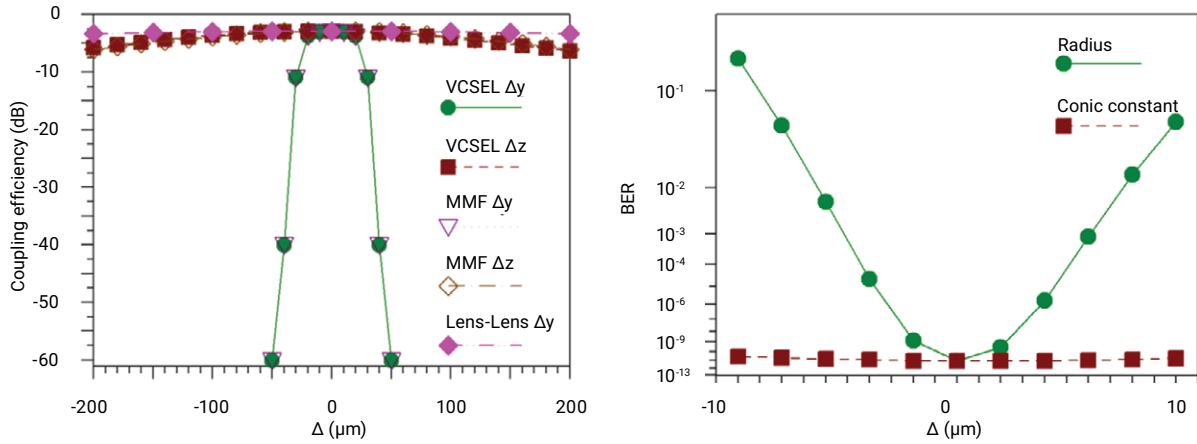

Figure 8: VCSEL-to-fiber coupling efficiency (left) and the system performance as a function of variations in the lens radius and conic constant (right)

The study shows that the lens assembly design gives high tolerance to longitudinal misalignment and lens-to-lens lateral misalignment, thereby making it a good choice for VCSEL-to-MMF and lens-to-MMF packaging. The study also shows that the system bit error rate (BER) performance is highly sensitive to the manufacturing tolerance of radius compared to that in the conic constant.

B.3: Variations in the Spot-Size Converter (SSC) Geometry and Impact on the System Performance

This case study uses co-simulation between the RSoft system modeling tool OptSim and the device modeling tool RSoft BeamPROP™. The SSC design is based on References [4-5]. The component is modeled in BeamPROP and is intended to couple the optical field from a single-mode fiber into a silicon rib waveguide. Figure 9 shows the layout in BeamPROP that is analyzed in OptSim using co-simulation.

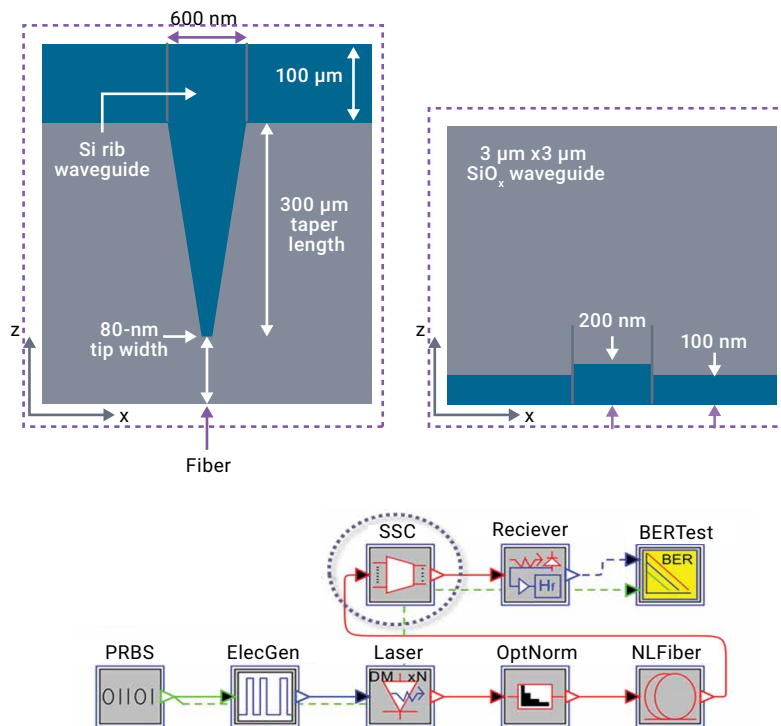

Figure 9: The SSC layout in BeamPROP (top left and right) and the co-simulation layout in OptSim

Figure 10 shows system BER performance as function of SSC parameters.

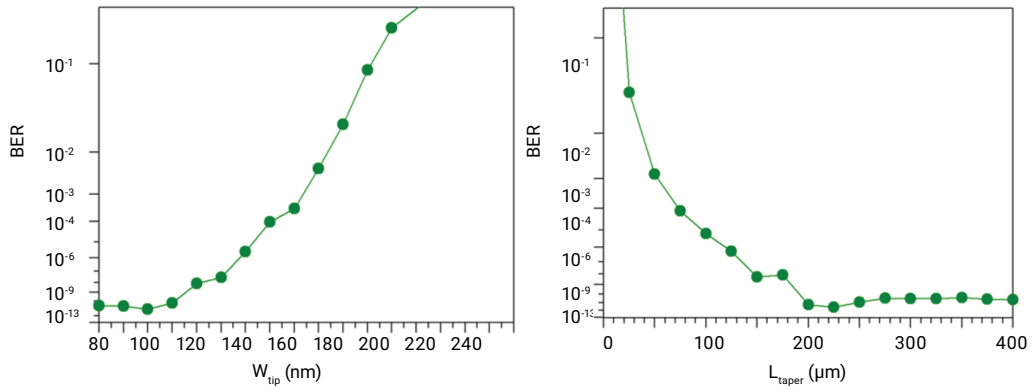

Figure 10: Impact of the SSC tip-width (left) and taper length (right) on the system

The study shows significant performance degradation for SSC designs having tip-widths exceeding 200nm and taper lengths lower than 200μm.

B.4: Variations in the Grating Coupler Device Geometry and Fiber Alignments

This case study demonstrates co-simulation between RSoft OptSim and the device modeling tool RSoft FullWAVE™. The SSC design is based on Ref [6]. The component is modeled in FullWAVE and is intended to couple the transverse electric mode of an optical waveguide into an optical fiber. Figure 11 shows the layout in FullWAVE that is analyzed in OptSim using co-simulation.

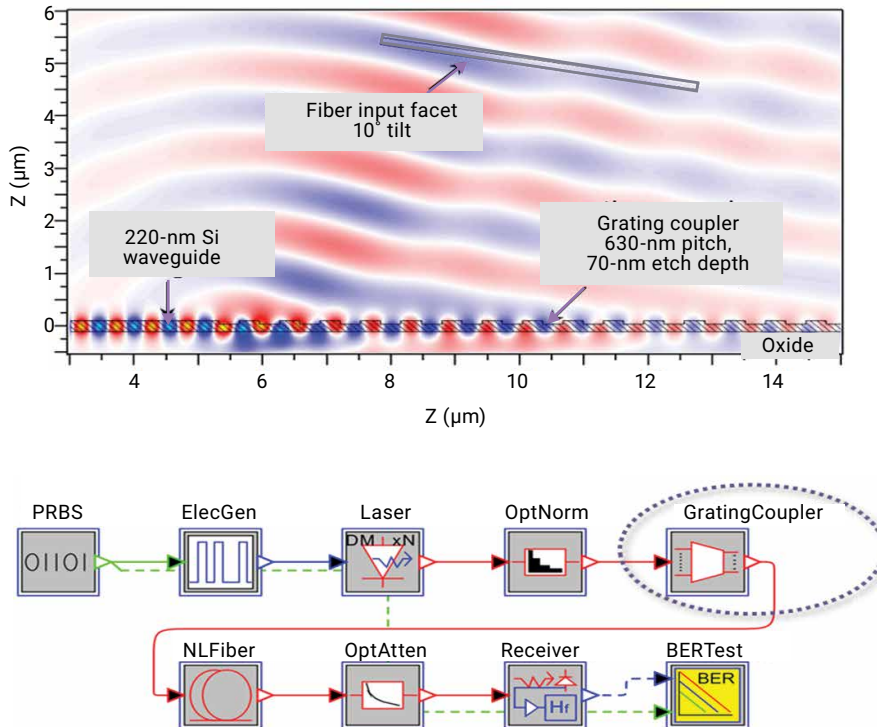

Figure 11: The grating coupler design in FullWAVE (top) and the co-simulation layout in OptSim

Figure 12 shows system BER performance as function of the grating coupler geometry and alignment variations.

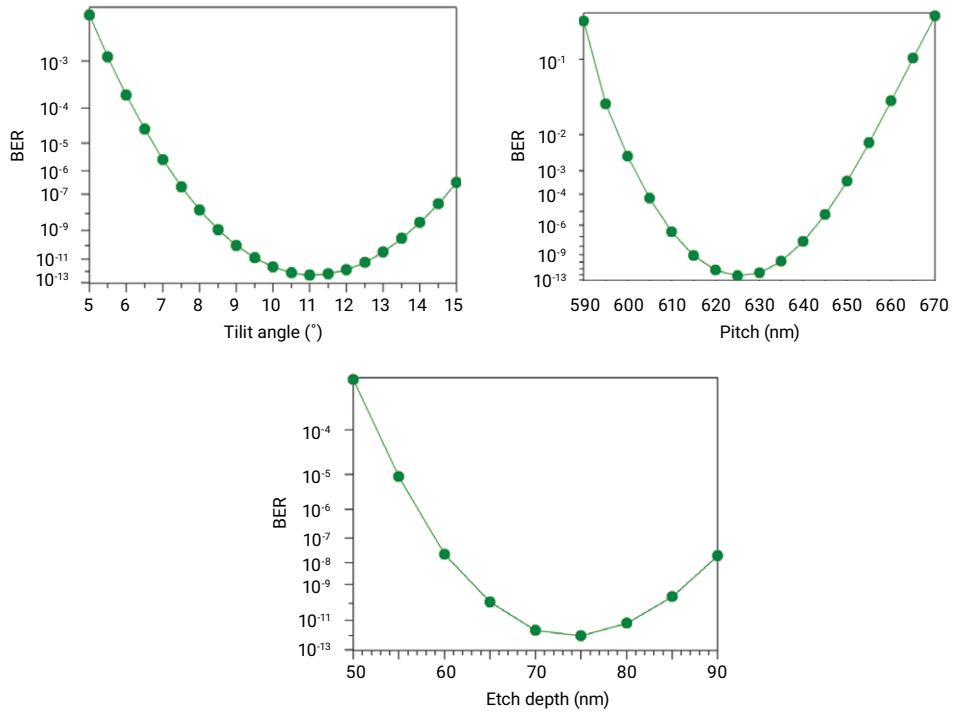

Figure 12: Impact of the grating coupler alignment (top left) and geometry (top right, bottom) on the system

The study demonstrates the benefit of optimizing grating coupler design within a system context and understanding the tolerance-to-parameter variations.

B.5: Choosing an Integrated Coherent Transmitter (ICT) for High-Speed Coherent Fiber-Optic Systems

This case study uses co-simulation between RSoft system modeling tools OptSim and OptSim Circuit. The study involves designing photonic integrated circuits (PICs) of coherent transmitters using polarization multiplexed quadrature phase shift keying (PM-QSK) modulation format. A comparison is made between the ICTs using silicon ring modulator and standard LiNbO3 Mach-Zehnder Modulator (MZM). The silicon ring modulator (RM) design is based on Ref [7]. The PIC modeled in OptSim Circuit and OptSim is used to model coherent receiver and digital signal processing (DSP). Figure 13 shows the schematic of the setup (the actual layout is too big to show legibly in a screenshot of the software interface).

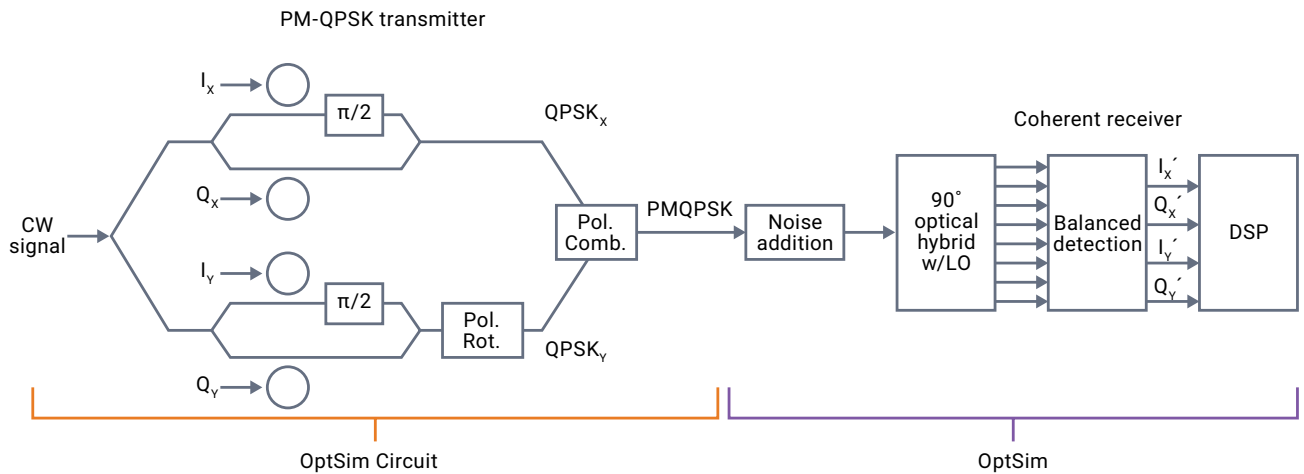

Figure 13: The schematic layout for this case study

Figure 14 shows system BER performance as a function of the grating coupler geometry and alignment variations.

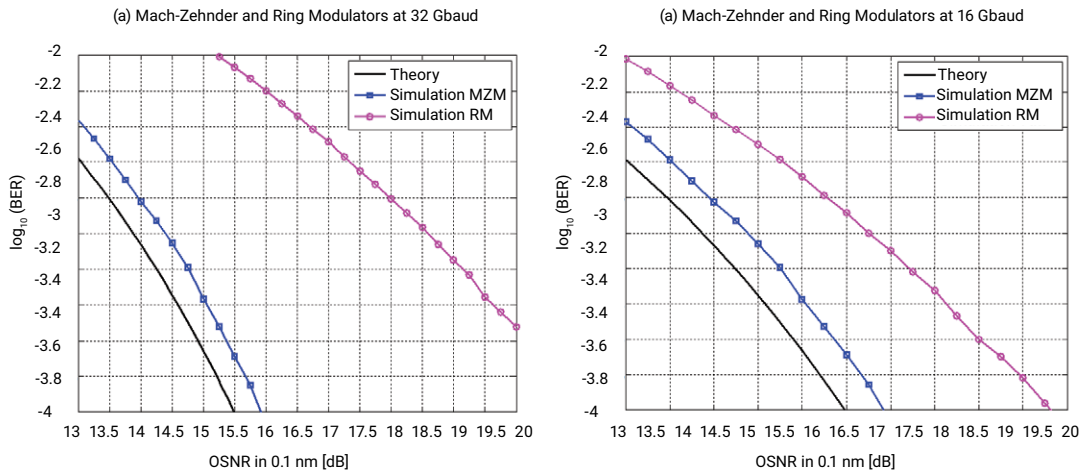

Figure 14: Comparison between the two ICTs at (a) 32 Gbaud and (b) 16 Gbaud data rates

The study demonstrates that the silicon-ring-modulator-based ICT used in this case does not perform well for application in PM-QPSK coherent systems when compared to the ICT using a standard LiNbO3 MZM. It is also shown [8] that the silicon-ring-modulator-based ICT demands stringent temperature control.

C. Case Study Based on Manual Exchange of Data Between the Modeling Tools

C.1: Photonic Crystal Fiber (PCF) as an All-Optical Wavelength Converter

Wavelength conversion helps provide an important data traffic routing functionality in modern, dynamically reconfigurable fiber-optic networks. An all-optic wavelength conversion (without optical-to-electrical and vice versa conversions) helps reduce both the number of components and overall network operational costs. This case study uses the RSoft device modeling tool FemSIM™ for modeling a PCF. The data is then used in OptSim to evaluate the PCF's suitability as an all-optical wavelength converter [9]. Figure 15 shows the PCF layout in FemSIM and simulation results data for using in OptSim.

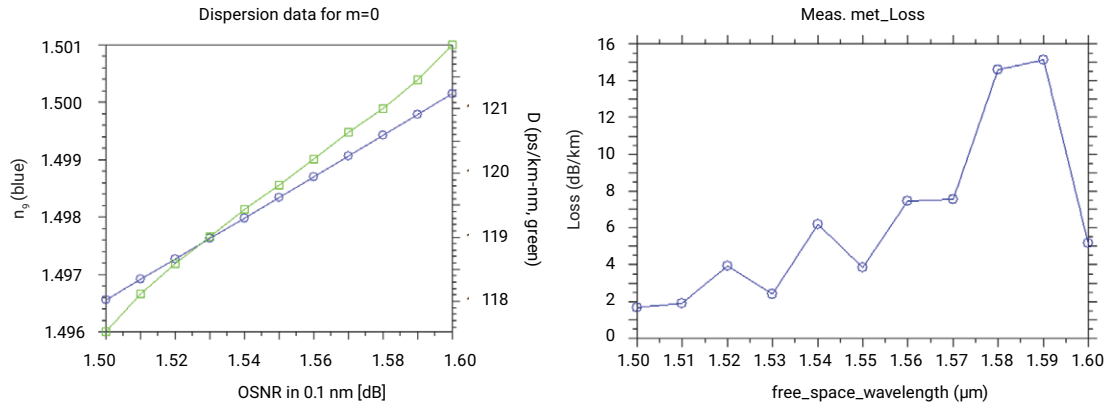
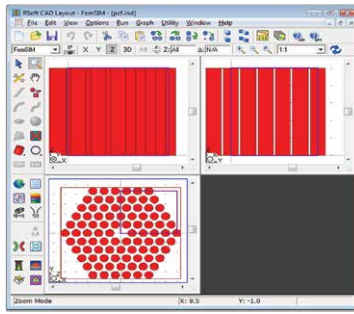

Figure 15: The PCF layout in FemSIM (top) and dispersion and loss data (bottom) for using in OptSim

Figure 16 shows the OptSim layout for all-optical wavelength conversion using FemSIM's PCF data and simulation results showing successful all-optical wavelength conversion.

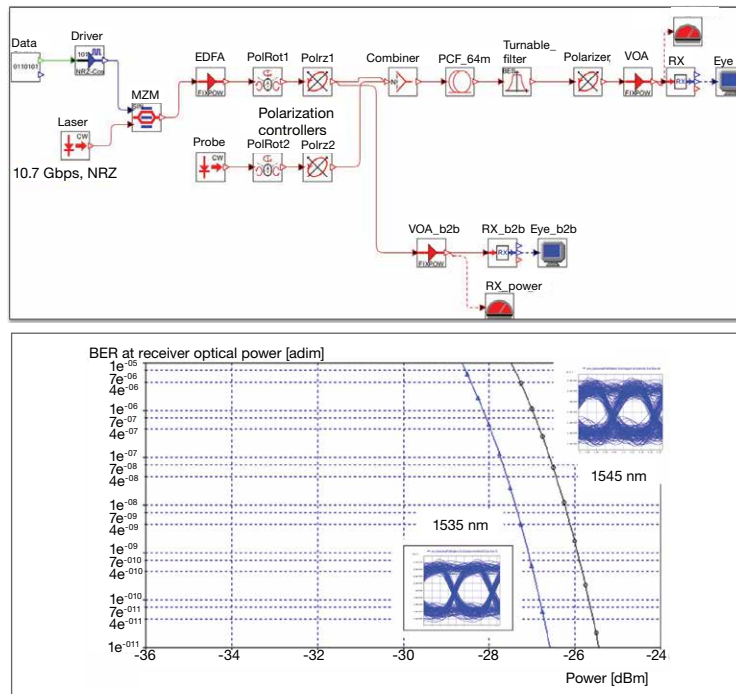

Figure 16: The all-optical wavelength converter layout in OptSim using FemSIM data (top) and results of a successful wavelength conversion

Using OptSim, a PCF component vendor can demonstrate to customers that the component can be successfully deployed in optical networks for the purpose of all-optical wavelength conversion.

Summary

Whether you are an optical/photonic component manufacturer or a vendor, you want your customers to succeed. Even though your component design team uses dedicated device modeling tools, using the RSoft Photonic System Design Suite gives you a number of unique benefits over your competitors. In this white paper, we presented a number of case studies to show how the RSoft Photonic System Design Suite can help streamline the production process (savings in operating and capital expenditures) and boost revenue with product marketing.

Acknowledgements

A number case studies presented here wouldn't be possible without the technical help and underlying work from my colleagues Enrico Ghillino, Dr. Pablo Mena, Dr. Bryan Stone, Dr. Chenglin Xu, Dan Herrmann, and Dr. Dwight Richards.

To Learn More

At synopsys.com/optical-solutions/rsoft.html, you can find detailed RSoft product information, application notes, e-newsletters, and the RSoft product catalog. You can also contact us at optics@synopsys.com to request more information and a 30-day evaluation of our software solutions.

References

- [1] Mena, P.V., Stone, B., Heller, E., Herrmann, D., Ghillino, E., Scarmozzino, R., "Mixed-level optical-system simulation incorporating component-level modeling of interface elements," Optical Interconnects XIV, Proc. SPIE 8991, 899111 (2014).
- [2] Sakai, K., Kawano, M., Aruga, H., Takagi, S.-I., Kaneko, S.-I., Suzuki, J., Negishi, M., Kondoh, Y. and Fukuda, K.-I., "Photodiode packaging technique using ball lens and offset parabolic mirror," Journal of Lightwave Technology 27(17), 3874-3879 (2009).
- [3] Lee, H.-S., Lee, S.-S. and Son, Y.-S., "High tolerance receptacle type active optical interconnect incorporating collimated beam based optics," Journal of Lightwave Technology 31(5), 815-821 (2013).
- [4] Tsuchizawa, T., Yamada, K., Watanabe, T., Park, S., Nishi, H., Kou, R., Shinojima, H. and Itabashi, S.-I., "Monolithic integration of silicon-, germanium-, and silica-based optical devices for telecommunications applications," IEEE Journal of Selected Topics in Quantum Electronics 17(3), 516-525 (2011).
- [5] Hiraki, T., Nishi, H., Tsuchizawa, T., Kou, R., Fukuda, H., Takeda, K., Ishikawa, Y., Wada, K. and Yamada, K., "Si-Ge-silica monolithic integration platform and its application to a 22-Gb/s x 16-ch WDM receiver," IEEE Photonics Journal 5(4), 4500407-4500407 (2013).
- [6] Taillaert, D., Van Laere, F., Ayre, M., Bogaerts, W., Van Thourhout, D., Bienstman, P. and Baets, R., "Grating couplers for coupling between optical fibers and nanophotonic waveguides," Japanese Journal of Applied Physics 45(8A), 6071-6077 (2006).
- [7] Yu, H., Korn, D., Pantouvaki, M., Campenhout, J. V., Komorowska, K., Verheyen, P., Lepage, G., Avsil, P., Hillerkuss, D., Alloatti, L., Leuthold, J., Baets, R., and Bogaerts, W., "Using carrier-depletion silicon modulators for optical power monitoring," OPTICS LETTERS, 37(22), 4681-4683 (2012).
- [8] Ghillino, E., Mena, P., Curri, V., Carena, A., Patel, J., Richards, D., and Scarmozzino, R., "Simulation of silicon photonic coherent PM-QPSK transceivers using micro-ring modulators," 2014 International Conference on Transport Networks (ICTON), July 6-10, Graz, Austria.
- [9] Kwok, C. H., Chow, C. W., Tsang, H. K., and Lin, C., "Nonlinear polarization rotation in a dispersion-flattened photonic-crystal fiber for ultra wideband (>100 nm) all-optical wavelength conversion of 10 Gbit/s non-return-to-zero signals," OPTICS LETTERS, 31(12), 1782-1784 (2006).