

“I was impressed with the intuitive user-interface, the powerful trigger capabilities, and the fact that there was no impact on FPGA performance and no changes to the design flow. The Identify solution simply works as advertised.”

Andreas Gravinghoff
Sr. Product Engineer
ETAS



Synplicity®

Simply Better Results

Using Identify® software in automotive applications

Identify Success Story

Summary

ETAS recently evaluated the Identify® RTL debugger from Synopsys' Synplicity Business Group, which was subsequently added to the standard development flow for VHDL-Based designs due to the outstanding success with this tool. The evaluation showed that a significant amount of time and resources can be saved during FPGA debugging using the Identify solution instead of traditional approaches.

ETAS was founded as a subsidiary of Robert Bosch GmbH in June 1994 with 42 employees and annual sales of 6.8 million. Since then, ETAS has grown to the global ETAS Group with 850 employees and annual sales of 148 million. The ETAS Group, i.e. ETAS, LiveDevices, Vetronix, has locations in Germany, the United States, Japan, Korea, France, and the UK.

All products and services of the ETAS Group focus on automotive software engineering and address three challenges:

- The standardization of software architecture.
- The introduction of efficient processes, methods and tools for development, production, and service of a vehicle.
- Data standardization throughout the entire vehicle life cycle.

ETAS customers include all major vehicle manufacturers and OEMs.

The ETAS tool family — comprised of the ASCET, INTECRIO, INCA, RTA, ODX, and LABCAR software product families, as well as the E5300, ES500, ES600, ES700, ES1000, ES4000, and ETK hardware product families — consistently supports all phases of development within the V cycle, with particular consideration of automotive requirements as well as all essential standards.

The Identify product was evaluated during the development of the ES1325, a digital I/O board targeted at rapid-prototyping applications for the ES1000 system. The modular ES1000 system is used for integrating, verifying, and validating application software functions in the vehicle. This series is specified for harsh automotive environments and combines outstanding computational power with unique I/O performance for all relevant ECU interfaces, bus interfaces, as well as sensor and actuator interfaces.

The ES1325 supports 16 digital output channels, 16 digital input channels, as well as two trigger channels. The individual channels can be configured independently in a flexible way in order to cover all possible use cases for measuring and generating digital signals.

The corresponding functionality is implemented in the FPGA, which contains a large number of custom IP cores connected by an internal bus. The custom IP cores were synthesized using the Synplify Pro® advanced FPGA synthesis solution, the standard tool in the ETAS development process for VHDL synthesis.

Identify Success Story

"I always wanted to test the Identify product since the technology looked very promising," says Andreas Grävingshoff, senior product engineer at ETAS. The opportunity for the Identify solution came as one of the ES1325 prototypes showed intermittent failures in the ES1000 system. Under normal circumstances, a logic analyzer with a VME bus probe would have been used to monitor the VME bus in order to determine the cause of the problem — unfortunately, all logic analysers had just been sent away for their annual calibration. "Thanks to the good support from Synplicity®, we were able to fix the problem on the same day!"

Immediately after receiving the evaluation license, the FPGA was instrumented, re-implemented, and debugged. "I was impressed with the intuitive user-interface, the powerful trigger capabilities, and the fact that there was no impact on FPGA performance and no changes to the design flow. The Identify solution simply works as advertised," said Grävingshoff.

It turned out that failures were not caused by a logical problem, but that the external clock signal was violating the stability requirements for the FPGAs DLL under certain circumstances — the FPGA logic was changed slightly to cover this fact. "Without the Identify tool, it would not have been possible to pinpoint this fleeting problem so easily, days would have been spent trying to observe the VME state machine using dedicated debug pins and a logic analyzer."

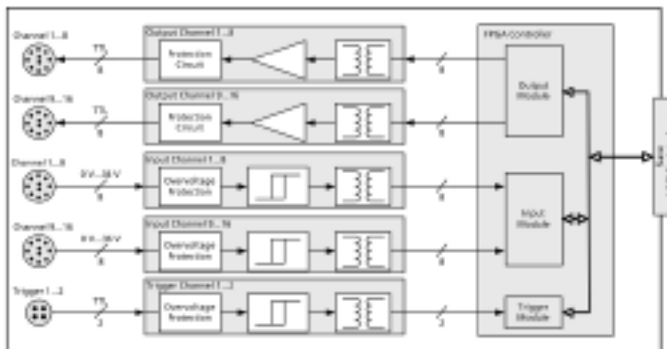

ES1325.I Block Diagram

After this encouraging experience, the Identify solution was successfully used during the ES1325 HW/SW integration process. Although test benches and unit tests were extensively used during the development of the custom IP cores and software drivers, some bugs were not detected until this stage, e.g. erroneous programming of the FPGA control registers.

In one case, a bug was detected a few days before the release of the ES1325 — it was mandatory to find and fix the problem on the same day in order to keep the release date, otherwise there would have been no time for the comprehensive system release tests.

Again, the Identify tool came to the rescue — without this tool ETAS would have to postpone the release of the ES1325 product.

ETAS hardware products use FPGAs due to the tight time-to-market requirements in the automotive industry, and the need to support emerging standards as well as changing and/or additional user requirements. As a consequence, ETAS is one of the largest FPGA customers in Germany. Since the successful evaluation within the ES1325 project, the Identify product has joined the Synplify Pro solution in their hardware development process for VHDL-based designs.

The capabilities of the Identify tool are already taken into account during the design of subsequent projects. The need to provide dedicated debug pins on the FPGA and/or needle-bed adapters in order to debug the FPGAs user logic is less important, since the same goal can be achieved much more easily with the Identify software. More importantly, precious development time is saved, thus allowing ETAS to maintain the tight development schedules.

SYNOPSYS®
Predictable Success

Synopsys, Inc.
Synplicity Business Group
600 West California Avenue
Sunnyvale, CA 94086 USA
www.synplicity.com

ETAS

30708SS