



carbon
design systems

Virtual Nirvana: Meeting the needs of the Virtual Platform Lifecycle

Synopsys Interoperability Forum

Bill Neifert, CTO

SOFTWARE BEFORE **SILICON**

Company Overview

- Founded in 2002
- Leading supplier of system level modeling & validation tools
 - Architectural trade-off analysis and validation
 - Pre-silicon firmware development and optimization
 - Pre-silicon hardware-software system validation
 - Secure model delivery to customers
- In June'08
 - Acquired SoC Designer system level design platform from ARM
 - Entered model partnership to become sole provider for ARM IP
- Carbon offers industry's only complete system validation solution
 - Cycle-accurate system modeling
 - Cycle-optimized platform creation, execution, and analysis
 - Cycle-accurate models and model kits for ARM IP
- Production use at 16 of top 20 semiconductor companies worldwide

Obligatory Virtual Platform Methodology Slide

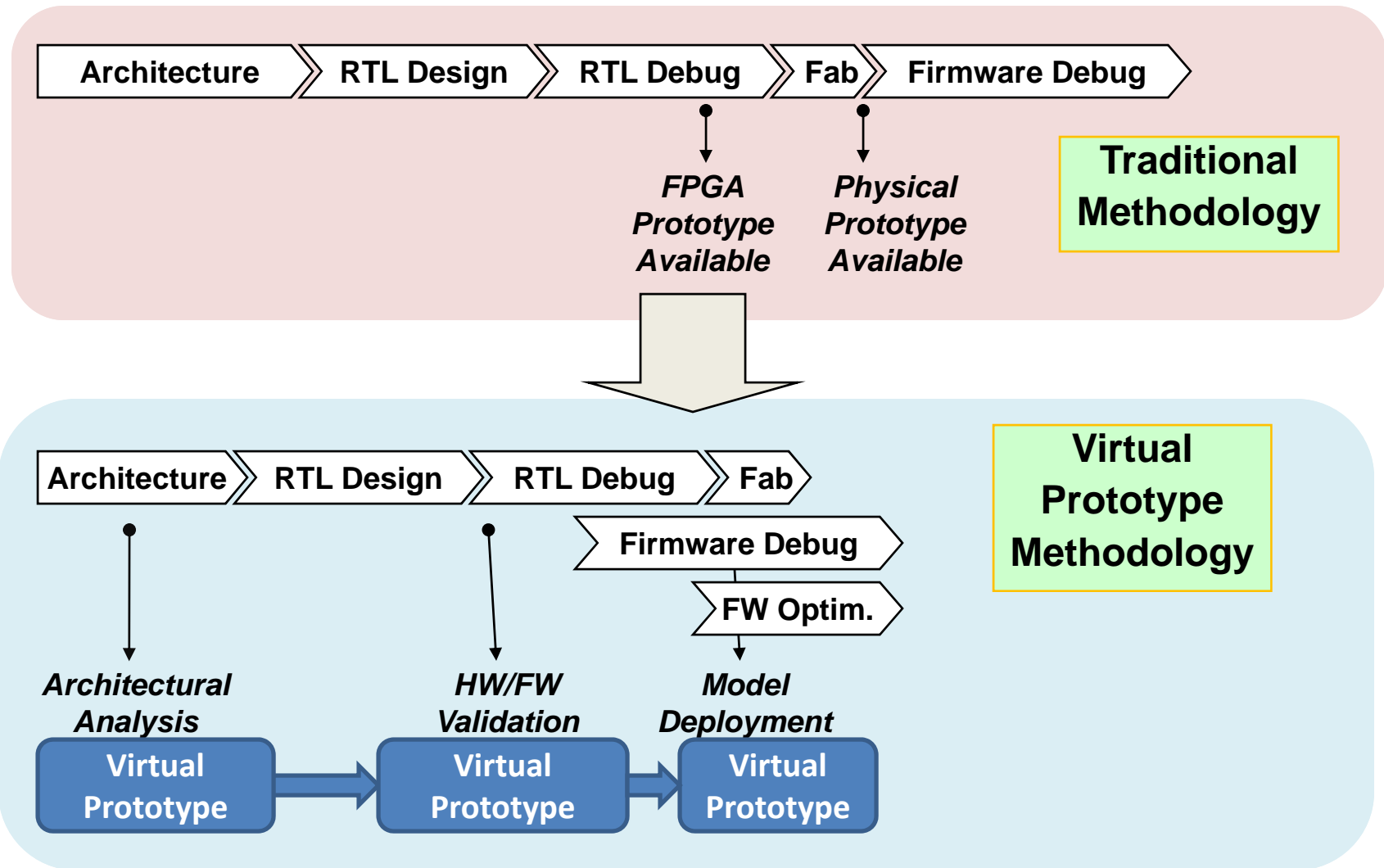

How accurately should I model?

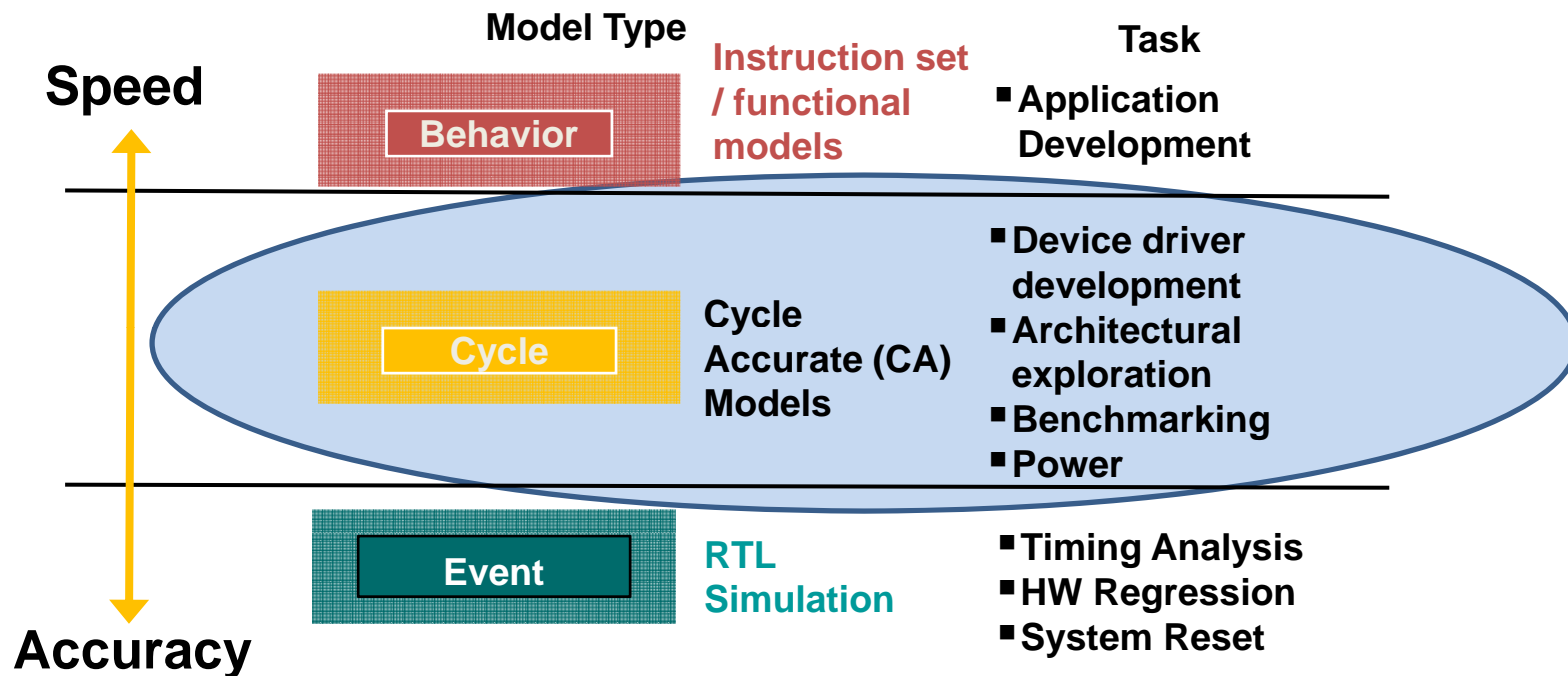

Modelling needs to make a compromise between accuracy and performance

- High levels of accuracy usually mean lower simulation performance
- High simulation performance usually requires more abstract (inaccurate) models

Projects will often require different levels of performance and accuracy at different stages of development

Why is accuracy important?

- **How do I characterize the performance of my SoC?**
 - What is the ideal bus, cache, and memory subsystem for my SoC?
 - What IP should I use?
 - What are the system's bandwidth and latencies?
 - Traffic analysis and congestion points
 - FIFO Queue Depths, Pipeline stalls, Data Races, Deadlocks
 - Multi-Core synchronization effects and stalls
- **Optimal performing firmware is fundamental to the performance of higher levels of software**
- **What is the Risk?**
 - Over-engineer the product because of inaccurate models
 - Over-engineer the hardware to compensate inefficient Firmware
 - Under-engineer the project possibly missing performance targets
 - Silicon Re-spin
 - Firmware not developed on time (missed schedule)
 - Firmware doesn't work with the hardware
 - Issues found late, usually in the Lab
 - Delays due to debugging complex HW/FW issues
 - Low confidence that the models you give your customers reflect how the IP really works

System Validation

How do I Validate Ultrasparc SW on new hardware design?

- Debug power-on self test software
- Debug OS drivers and Initial Boot sequence
- Validate new IO ASIC

Using CA Models and Virtual Platform

- 34 SW Bugs discovered AFTER SW correctly running on behavioural model, saving weeks of debug time in the lab
- 3 Hardware bugs found prior to tape-out saving re-spin
- First time in groups' history OS booted the very 1st day in the lab
- Used CA virtual prototype for validating error recovery SW even after chips came back

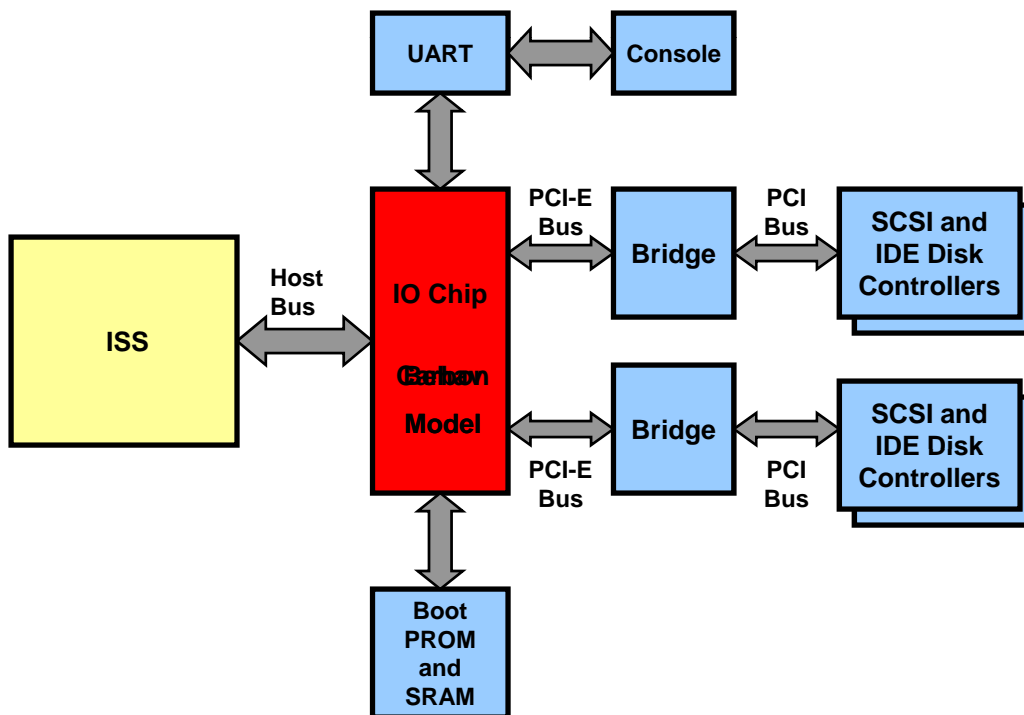

The Carbon Virtual System Lifecycle

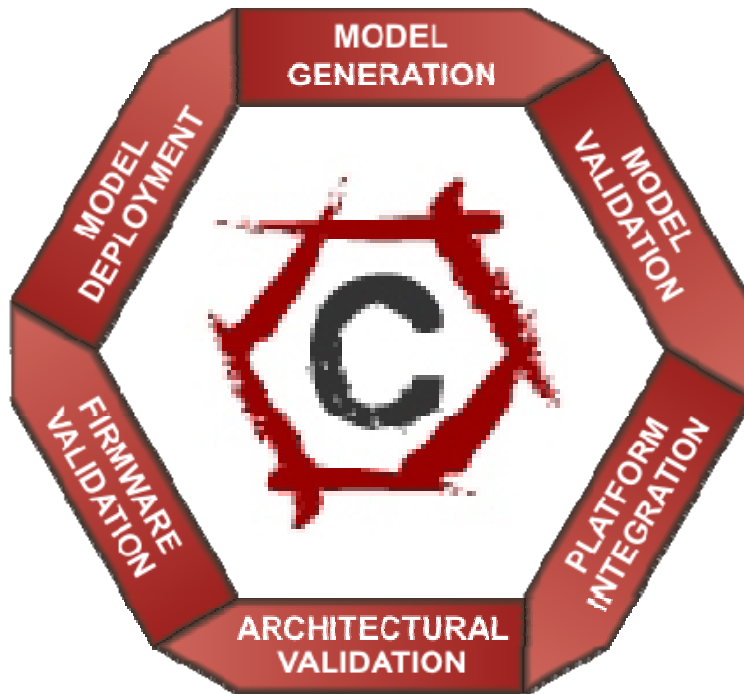

- Model Generation
 - Creating new models
- Model Validation
 - Verifying individual models
- Platform Integration
 - Creating virtual platforms
- Architectural Validation
 - Verifying the design decisions
- Firmware Validation
 - Verifying the FW components
- Model Deployment
 - Providing system models to the entire design chain

Model Generation

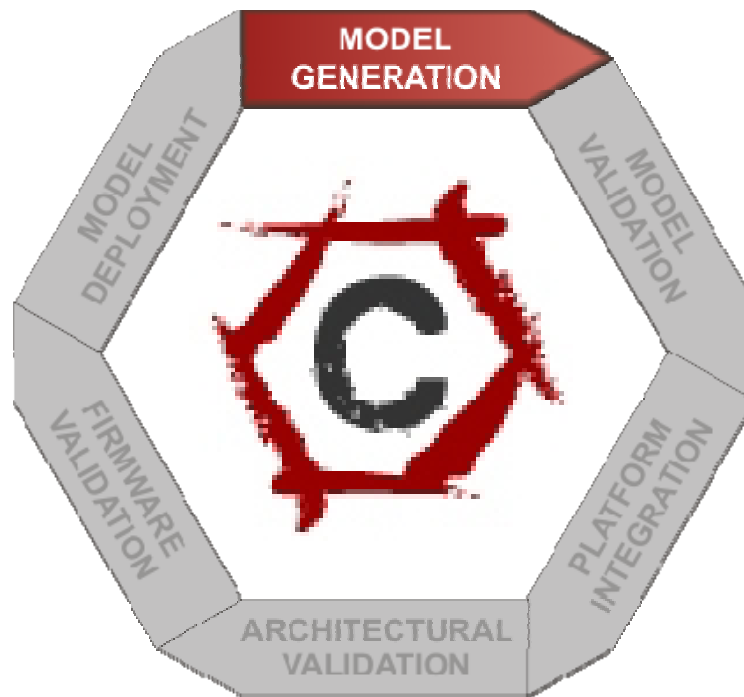

Model Generation



- Compiles RTL into fast, secure software object
- Retains 100% functional accuracy, hierarchy and register names
- Compiled binary object – no way to decrypt or obtain original source
- API gives access to all pins and internal registers
- In use today at 17 of top 20 semiconductor companies

ARM Cycle-Accurate IP Models

Carbon is the sole source for cycle-accurate ARM IP models

- Implementation Accurate: Created from the RTL using Carbon Model Studio
- Fully integrated with RealView Debugger
- Profiling and debug capabilities
- Includes CPU and Primecell IP
- 25+ IP Models available today



Platform Integration

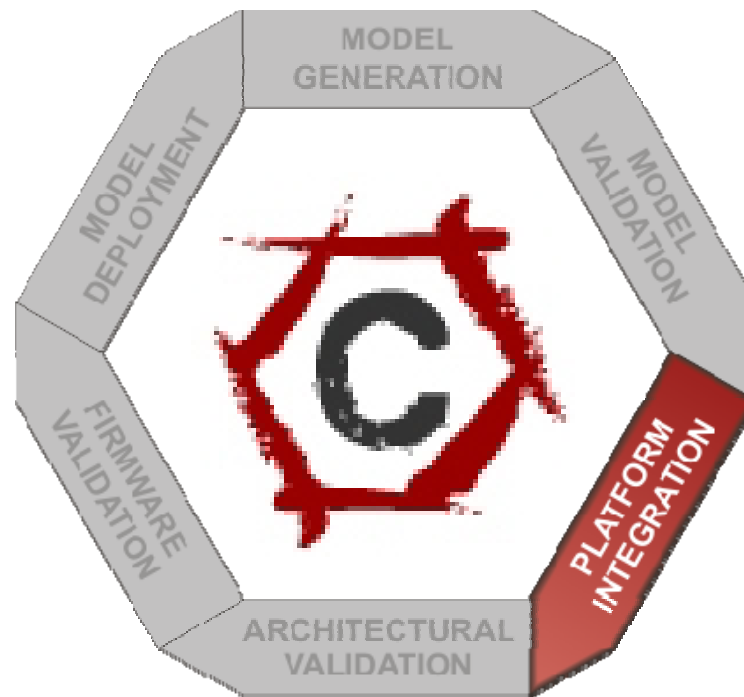

Carbon Model Targets

- Carbon models support all popular platforms
- All Carbon products based on open standard interfaces
 - OSCI, Spirit, IEEE, etc.
- Carbon's API's and component wizards make it easy to integrate into all platforms
- Extensive transactor library reduces integration effort



AMBA TLM-2.0 Today

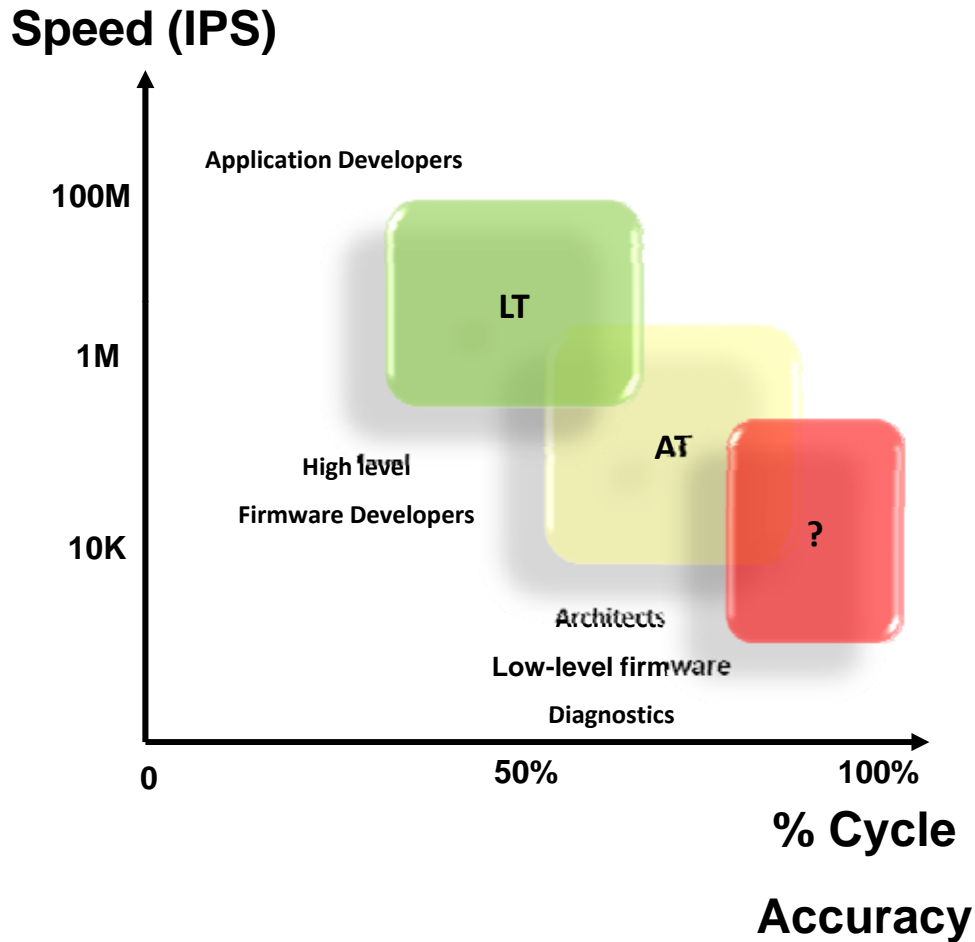

- LT
 - ARM Fast Models
 - De facto standard only, not yet published
- AT
 - No widely available models
 - Proprietary solutions
- CA
 - No TLM-2.0 definition
 - Carbon models of ARM IP
 - Pin level interconnect only
- No standardized connection between levels of abstraction

AMBA TLM-2.0

- Carbon is driving and coordinating industry effort to standardize TLM -2.0 extensions for AMBA
- Carbon will provide a freely downloadable specification and open source kit for AMBA TLM-2.0
 - Payload extensions which cover LT, AT and CA for AXI, AHB, AHB-Lite and APB
 - Adapters between LT and CA
 - Adapters between CA and Carbon pins
- Carbon leading industry review to deliver standardized extensions
 - ARM
 - GreenSocs
 - Synopsys and other leading EDA, ESL and systems companies reviewing and augmenting
- These extensions enable simple interchange of models at any level of TLM-2.0 abstraction

Architectural Validation

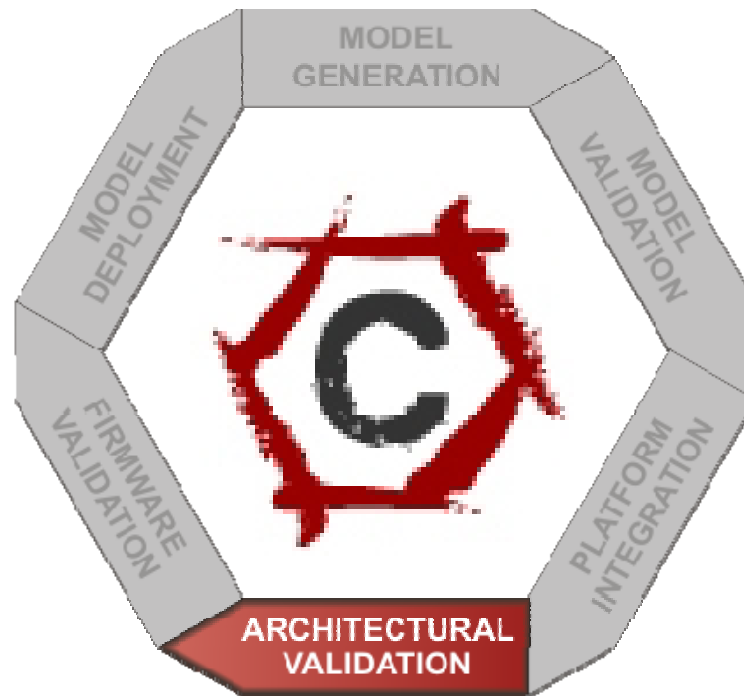

Architectural Analysis

What cache size do I need for MPEG4 decode?

- Requires cycle accuracy
- Requires significant number of simulation cycles
- Hours becomes minutes with a Virtual Platform

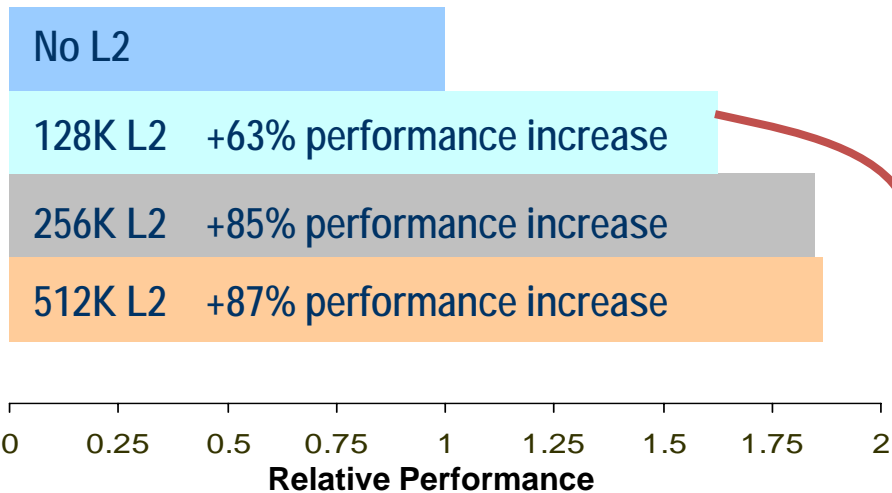

Benchmark : MPEG4 decode QCIF (foreman bitstream)
 System : ARM1176ZJ-S / L220 / PL340
 CPU : 400MHz ARM1176ZJ-S 16K I & D caches
 Memory : 100MHz 32 bit DDR SDRAM, ARM PL340

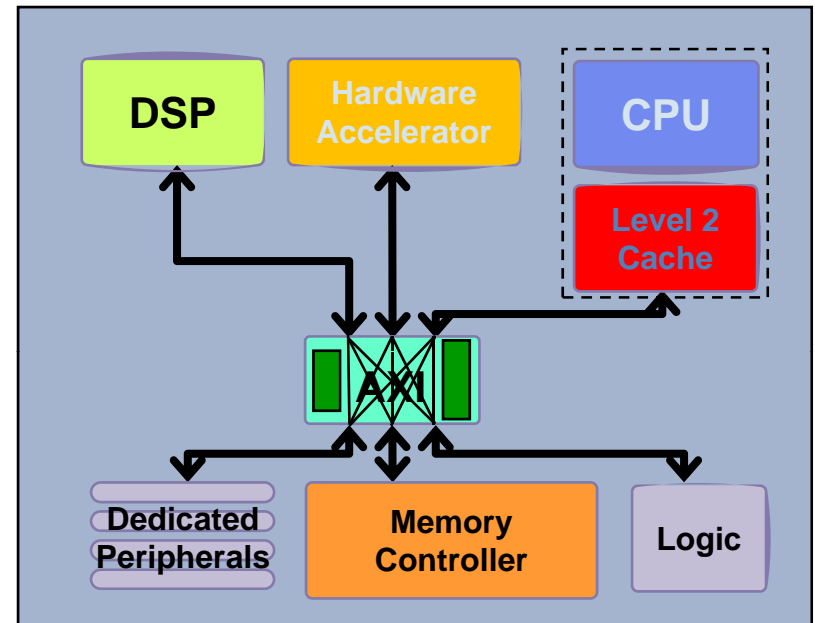

63% increase

3.5mm²

128K L2 cache
50mm² SoC on
TSMC 90nm

Best performance / cost trade-off

Firmware Validation and Tuning

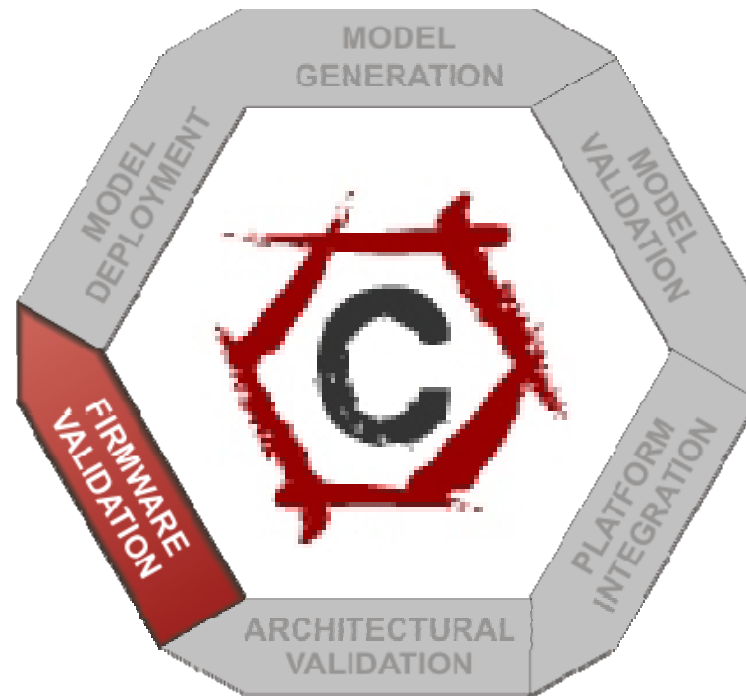

SoC Designer for Firmware Validation

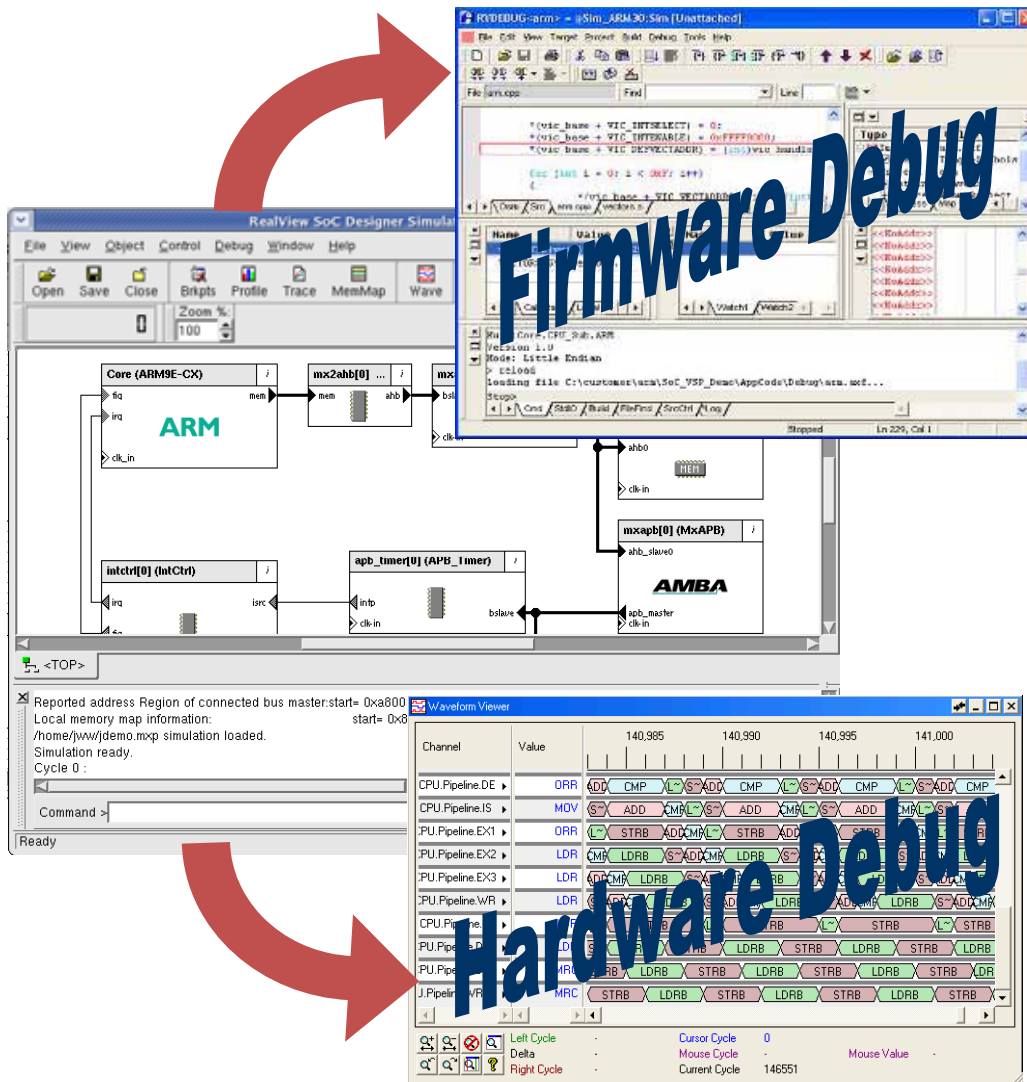

SoC Designer provides the performance and accuracy for Firmware debug

- Native debug tools for both domains
 - Debugging tools provide both hardware-centric and firmware-centric views
- Fully integrated with ARM's Realview Development Suite
- Complete system visibility
 - Combined hardware and firmware views of the platform allow easy debugging across both domains
- Control data values in either firmware or hardware views
- Set Breakpoints in the firmware debugger or in the hardware
- Multi-Core support

Firmware Validation

How to validate FW on a next generation Network Storage processor?

- Previous FPGA prototype solution too complex and costly (7 FPGA's required)
- 3 month development time for multiple engineers
- Debug/Bug Fix turn time very slow (1 week ave)

Cycle Accurate Models and Virtual Platform provided a better solution

- Environment up and running 6 months prior to tape-out
- FW bugs identified, debugged and fixed in **single day**
- Environment easier to set up and configure compared to real HW
- Easier to debug than real HW (can freeze system time)
- Easier to support SW developers in India compared to shipping and supporting FPGA prototypes
- **Found HW bugs** that would have been missed by the Verification team
- **SW up and running the first day in the lab!**

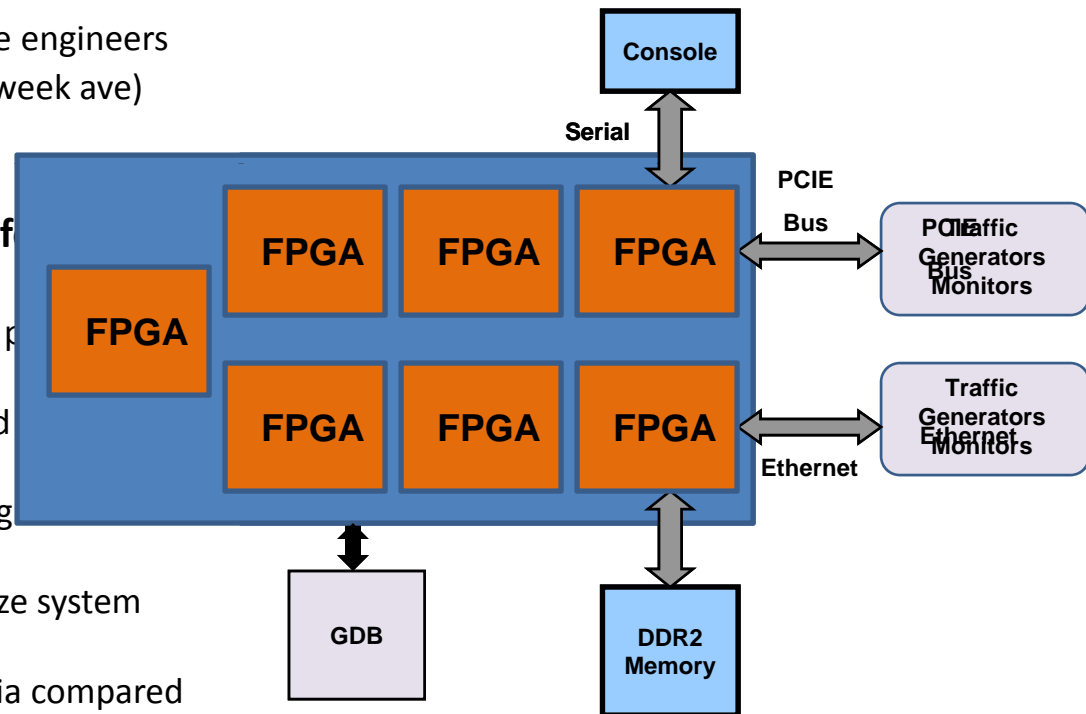

Model Deployment

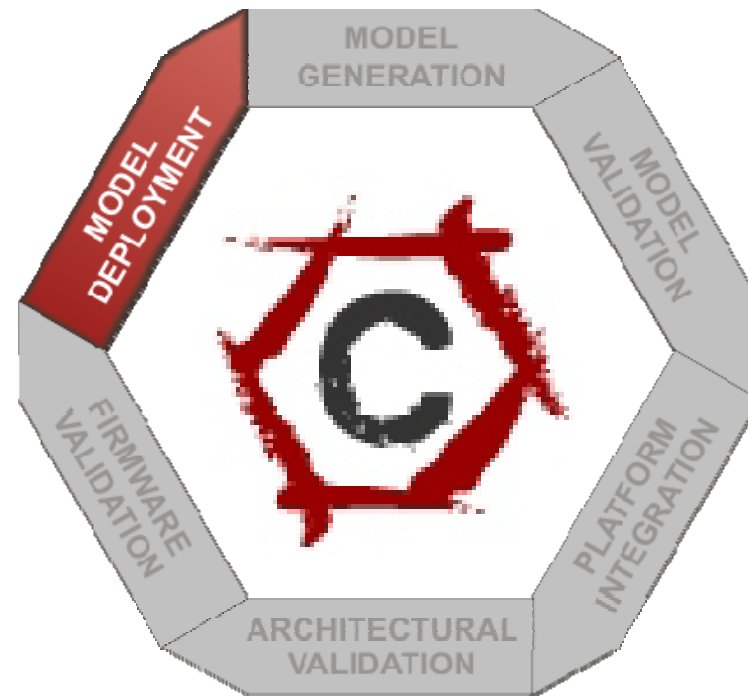

Model Deployment

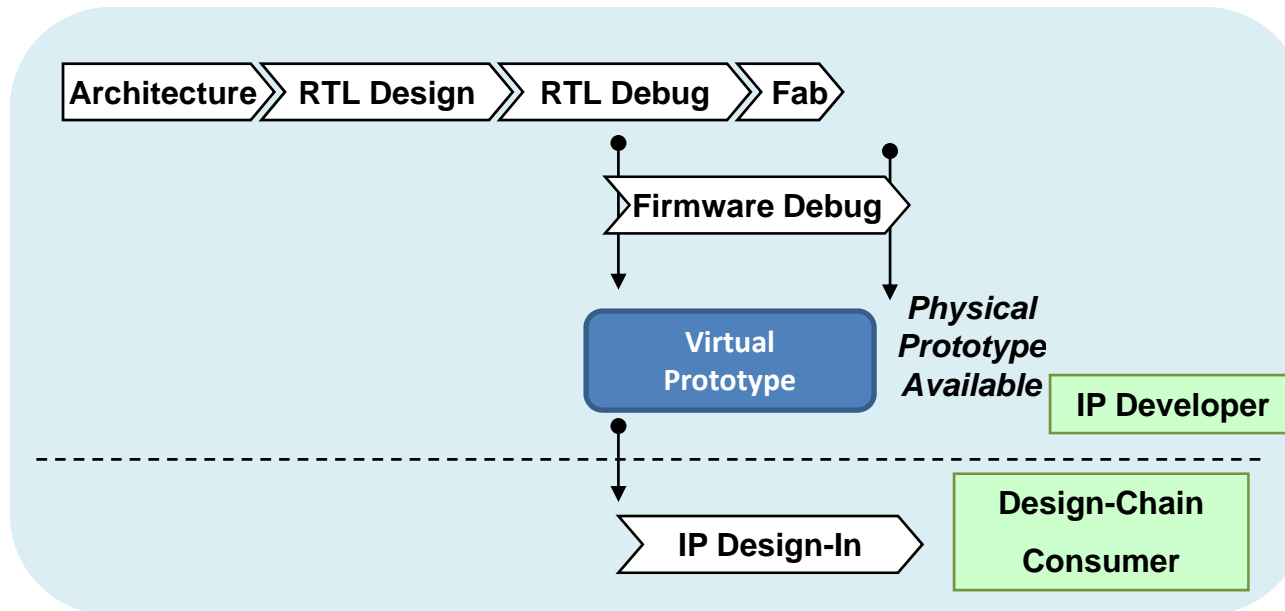

**Example: AMCC
nP370 SDK is based
on Carbonized
models**



- Carbon Model Studio provides protection for your golden RTL by distributing binary compiled models
- Carbon SoC Designer enables easy creation of virtual platform reference systems to distribute with your IP
- SoC Designer's platform generator creates encrypted platform models for wide deployment
- Control visibility and access to model functionality
- Deliver both high-performance and accuracy required by your design chain

Summary

- Carbon Model Studio is today's standard for system level model generation
- Carbon is the sole source for cycle accurate models for ARM IP
- Only Carbon provides a complete system level modeling & validation solution
- Enables platforms that can be brought up and add value to your team in a matter of hours or days
- Carbon leadership
 - Over 50 customers in production using SocD and/or CMS
 - 87% growth in 2008, 108% growth in Q4, 2008
 - 27 new customers in 2008